

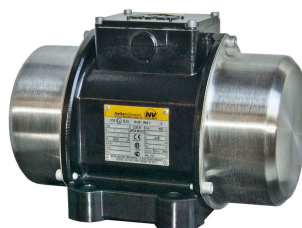

NetterVibration In the Industry

- Loosening product compaction
- Eliminating bridging
- Loosening stubborn adhesions
- Maintaining product flow
- Compacting materials
- Driving conveyor trays





NetterVibration



Vibrators For Industrial Purposes



Loosening hard crusts
with pneumatic linear vibrators



Loosening product compaction
with pneumatic circular oscillators



Gentle conveying and dosing of
bulk materials with conveyor trays



Sieving coarse bulk material
with electric external vibrators



Conveyor sieving tray, driven by stainless
steel electric external vibrators

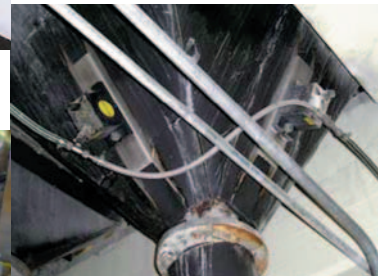

Eliminating bridging with
pneumatic circular oscillators



Compacting / levelling materials in a production
line with a vibrating table



Easing, loosening
wire coils with
electric external
vibrators



Conveying with stainless steel
electric external vibrators

Applications

Vibrators supplied by **NetterVibration** are used in many industrial branches.

Applications include simple loosening of adhesions, maintaining product flow and compacting.

A special part of vibration technique is conveyor technology. The systematic use of resonance effects and material properties allows conveyor performances which would require considerable effort if other technologies were used.

In addition to the standard devices, **NetterVibration** offers a wide range of special solutions, adapted to suit the

individual requirements of the client.

NetterVibration has a worldwide staff of experienced application engineers and field representatives. We would be pleased to offer advice on site and to help optimize your applications using vibration technology.

We would be pleased to prove our consulting competence in connection with a free trial of our test units.

Netter provides solutions. Consult our experienced application technicians.

Netter GmbH

Germany

Fritz-Ullmann-Str. 9
55252 Mainz-Kastel
Tel. +49 6134 2901-0
Fax +49 6134 2901-33

Switzerland

Erlenweg 4
4310 Rheinfelden
Tel. +41 61 8316200
Fax +41 61 8311291

Poland

Al. W. Korfantego 195/17
40-153 Katowice
Tel. +48 32 2050947
Fax +48 32 2051572

www.**NetterVibration**.com
info@**NetterVibration**.com



NetterVibration

Unbalance Type XL Unbalance Type XM Unbalance Type XS



Netter Electric External Vibrators
 Series NEG 3-Phase
 Series NEA Single Phase
 Series NED Direct Current

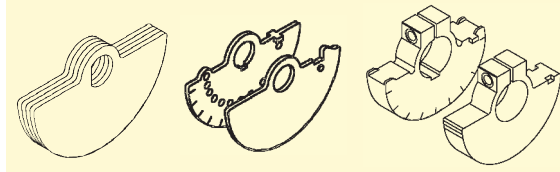

min ⁻¹	Type	Housing		Unbalance [cmkg]		Centrifugal Force [N]		EE ^e II ^{**}	Power Input [kW]				Nominal Current [A]				
		Size	Material	NEG/NEA		NEG/NEA			NEG E	NEG		NEA		NEG		NEA	
				50 Hz	60 Hz	50 Hz	60 Hz			50 Hz 400 V	60 Hz 480 V	50 Hz 230 V	60 Hz 115 V	50 Hz 400 V	60 Hz 480 V	50 Hz 230 V	60 Hz 115 V
3000 3600	NEA 504*	50	Al	0,08	0,08	40	57	-	-	-	0,024	0,024	-	-	0,13	0,30	
	NEG/NEA 5020*	60	Al	0,39	0,39	192	277	-	0,035	0,035	0,035	0,035	0,15	0,15	0,17	0,42	
	NEG/NEA 5050*			0,91	0,91	450	647	-	0,045	0,045	0,045	0,045	0,16	0,16	0,20	0,46	
	NEG/NEA 5060	100	Al	1,272	1,272	627	904	-	0,12	0,12	0,11	0,11	0,27	0,23	0,56	1,52	
	NEG/NEA 50120	101	Al	2,4	2,4	1.185	1.708	-	0,18	0,18	0,165	0,165	0,35	0,30	0,75	1,52	
	NEG/NEA 50200			4,2	3,0	2.073	2.133	-	-	-	-	-	-	-	-	-	
	NEG/NEA 50300	110	Al	6,02	4,08	2.972	2.900	T3,T4	0,26	0,27	0,28	0,28	0,60	0,50	1,25	2,40	
	NEG/NEA 50550	120	Al	9,99	6,48	4.930	4.606	T3,T4	0,45	0,50	0,5	0,5	0,80	0,75	2,30	4,50	
	NEG/NEA 50770	130	Al	15,59	10,40	7.695	7.392	T3,T4	0,65	0,685	0,7	0,75	1,10	1,00	3,25	7,00	
	NEG 50980 NEG 501140	133	Al	19,8	13,2	9.772	9.382	T3,T4	1	1,2	-	-	1,75	1,75	-	-	
NEG 50980 NEG 501140	23,0			16,5	11.352	11.727											
1500 1800	NEG/NEA 2530	101	Al	2,4	2,4	296	426	-	0,085	0,095	0,09	-	0,21	0,20	0,43	-	
	NEG/NEA 2570			6,2	4,2	766	747										
	NEG/NEA 25210	110	Al	16,84	11,76	2.078	2.090	T4	0,17	0,17	0,21	-	0,41	0,40	1,00	-	
	NEG/NEA 25420 NEG/NEA 25540	120	Al	32,64	22,66	4.028	4.027	T3,T4	0,30	0,35	0,24	-	0,60	0,60	1,20	-	
	NEG/NEA 25420 NEG/NEA 25540			43,80	32,64	5.405	5.800										
	NEG/NEA 25700	130	Al	57,18	41,89	7.056	7.444	T3,T4	0,525	0,665	0,45	-	0,92	0,98	2,50	-	
	NEG 25930	133	Al	75,0	52,0	9.254	9.239	T4	0,55	0,68	-	-	0,95	0,95	-	-	
1000 1200	NEG 1630	110	Al	6,02	6,02	331	476	-	0,12	0,135	-	-	0,30	0,30	-	-	
	NEG 1690			16,84	16,84	924	1.330										
	NEG 16190	120	Al	32,64	32,64	1.790	2.578	T4	0,185	0,205	-	-	0,50	0,50	-	-	
	NEG 16310	130	Al	57,18	41,89	3.136	3.309	T4	0,35	0,38	-	-	0,72	0,68	-	-	
	NEG 16410 NEG 16500	133	Al	75,0	52,0	4.113	4.106	T4	0,35	0,38	-	-	0,75	0,67	-	-	
	NEG 16410 NEG 16500			90,7	66,5	4.974	5.251										-
	NEG 12100	120	Al	32,64	32,64	1.007	1.450	T3	0,23	0,25	-	-	0,85	0,76	-	-	
NEG 12180	130	Al	56,8	56,8	1.752	2.523	T3	0,35	0,38	-	-	1,10	1,05	-	-		
NEG 12230	133	Al	75,0	75,0	2.314	3.332	T4	0,28	0,30	-	-	0,60	0,68	-	-		
3000	NED 50100	102	Al	2,39		1.180		-	0,10 (12 V =)		0,10 (24 V =)		8 (12 V =)		4 (24 V =)		
	NED 50200	103	Al	4,21		2.080		-	0,19 (12 V =)		0,19 (24 V =)		16 (12 V =)		8 (24 V =)		
	NED 50500	122	Al	9,98		4.930		-	0,27		0,27		22,5		11,3		
3600	NED 601110	133	Al	15,6		11.087		-	0,53 (24 V =)				22 (24 V =)				

*Protection IP 65, **Technical data available upon request

Unbalance Type XLs

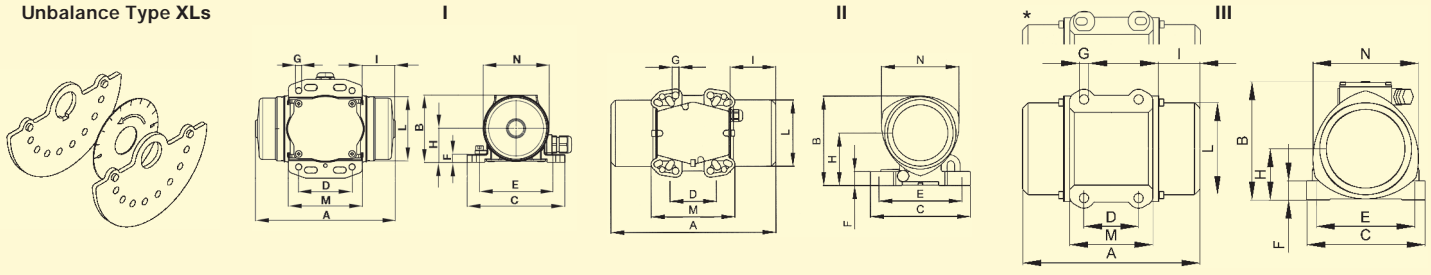

Type	Weight [kg]		Type of Housing	Dimensions [mm]													Unbalance [No. of Unbalance Discs]			
	NEG/NEA			NEG/NEA	NEG/NEA													Type	50/60 Hz	
	50 Hz	60 Hz			A	B	C	Mounting Pattern**			D	E	G	H	I	L	M			N
								n ₂	F	G										
NEA 504	1,00	1,00	I	111	67	90	25-40	75	4	9	5,5	34	24	63	59	65	XL	8		
NEG/NEA 5020	2,20	2,20	I	157	75	110	60	85	4	9	6,5	38	33	72	83	74	XL	8		
NEG/NEA 5050	2,45	2,45		25-40			92	6,5											39	
NEG/NEA 5060	4,9	4,9	II	197	121	125	60	100	4	20	8,5	71	33	92	86	105	XLs	4		
							62	95												
							65	85												
							70	106												
NEG/NEA 50120	5,9	5,8	II	207	143	165	62-74	106	4	25	13	86	44	100	156	123	XM	4		
							80	110												
							115	135												
NEG/NEA 50200	6,5	6,3	II	223	143	165	115	135	4	25	13	86	52	100	156	123	XM	4		
							135	115												
							124	110												
NEG/NEA 50300	10,2	10,0	II	247	173	165	65	140	4	25	13	103	50	124	156	146	XM	4		
							80	110												
							115	135												
							135	115												
							124	110												
							90	125												
NEG/NEA 50550	16,3	16,1	II	283	192	217	100	180	4	30	17	113	63	143	137	168	XM	4		
							105	140												
							13													
NEG/NEA 50770	22,6	21,6	III	308	212	238	100*	180*	4	43	17	94	63	168	163	193	XM	4		
NEG 50980	24,5	23,4	III	314	217	217	100	180	4	35	17	93,5	76	168	152	193	XM	4		
NEG 501140	25,0	24,0					92-128*	167-203*												
NEG/NEA 2530	6,1	5,8	II	207	143	165	65	140	4	25	13	86	44	100	156	123	XM	4		
							62-74	106												
							80	110												
							115	135												
NEG/NEA 2570	7,3	6,9	II	243	143	165	135	115	4	25	13	86	62	100	156	123	XM	4		
							124	110												
							65	140												
							80	110												
NEG/NEA 25210	12,8	11,8	II	307	173	165	115	135	4	25	13	103	80	124	156	146	XS	4		
							135	115												
							124	110												
							90	125												
							100	180												
							13													
NEG/NEA 25420	20,7	19,7	II	355	192	217	100	180	4	30	17	113	99	143	137	168	XS	4		
105	140																			
NEG/NEA 25540	22,7	21,7	II	391	192	217	100	180	4	30	17	113	117	143	137	168	XS	4		
NEG/NEA 25700	29,4	28,4	III	392	212	238	100*	180*	4	43	17	94	105	168	163	193	XS	4		
NEG 25930	34,2	32,7	III	442	217	217	100	180	4	35	17	93,5	140	168	152	193	XS	4		
NEG 1630	12,0	10,1	II	247	173	165	65	140	4	25	13	103	50	124	156	146	XM	4		
							80	110												
							115	135												
							135	115												
NEG 1690	12,7	12,7	II	307	173	165	124	110	4	25	13	103	80	124	156	146	XS	4		
							90	125												
							100	180												
							13													
NEG 16190	20,5	20,5	II	355	192	217	100	180	4	30	17	113	99	143	137	168	XS	4		
NEG 16310	28,9	27,9	III	392	212	238	100*	180*	4	43	17	94	105	168	163	193	XS	4		
NEG 16410	34,1	33,6	III	442	217	217	100	180	4	35	17	93,5	140	168	152	193	XS	4		
NEG 16500	36,1	35,1					92-128*	167-203*												
NEG 12100	20,5	20,5	II	355	192	217	100	180	4	30	17	113	99	143	137	168	XS	4		
NEG 12180	28,0	28,0	III	392	212	238	100*	180*	4	43	17	94	105	168	163	193	XS	4		
NEG 12230	34,6	34,6	III	442	217	217	100	180	4	35	17	93,5	140	168	152	193	XS	4		
NED 50100	5,7	II	204	147	162	65	140	4	25	13	88	45	100	157	117	XM	4			
						115/135	135/115													
						74/80	106/110													
NED 50200	6,0	II	253	147	162	65/115	140/135	4	25	13	88	53	100	142	117	XM	4			
						74/80	106/110													
						9/11														
NEG 50500	13,1	II	288	203	167	105	140	4	30	13	82,5	65	145	140	160	XM	4			
NEG 601110	20	III	308	215	205	120	170	4	45	17	94	63	168	160	182	XM	4			

*Variable mounting pattern see operating manual, **Recommended mounting pattern in bold type.



NetterVibration



Netter Electric External Vibrators Series NEG Single Phase

Unbalance Type XLs

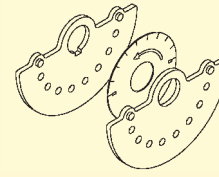

Unbalance Type XS

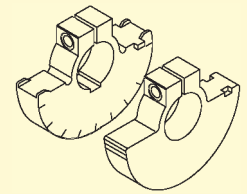

min ⁻¹	Type	Housing Size	Material	Unbalance [cmkg]		Centrifugal Force [N]		EEx e II *	Power Input [kW]		Nominal Current [A]		Weight [kg]		
				50 Hz	60 Hz	50 Hz	60 Hz		50/60 Hz	50 Hz 400 V	60 Hz 480 V	50 Hz 400 V	60 Hz 480 V	50 Hz	60 Hz
3000 6000	NEG 501540	140	AL	30,6	20,4	15.103	14.499	T3, T4	1,4	1,45	2,3	2,0	34,3	32,8	
	NEG 501800			35,8	25,6	17.669	18.195		T3	2,0	2,0	3,3	2,9	35,1	33,6
	NEG 502020	150	GGG	41,0	25,6	20.236	18.195	T3	2,2	2,2	3,5	3,0	49	47	
	NEG 502270			46,0	30,6	22.704	21.748		T3	2,2	2,2	3,5	3,0	50	49
	NEG 503400	170	GGG	65,6	43,7	32.364	31.052	-	3,8	3,8	6,2	5,4	106	102	
	NEG 503820			76,5	54,6	37.764	38.827		-	4,0	4,0	6,5	5,6	107	103
	NEG 506220	190	GGG	126,0	88,6	62.189	62.970	-	5,5	5,5	9,2	8,0	188	181	
NEG 508830	195	GGG	179,0	123,8	88.347	87.988	-	10,0	9,3	18,0	13,0	215	210		
1500 1800	NEG 251410	140	AL	112	80,0	13.820	14.215	T3, T4	0,9	1,05	1,45	1,5	44,8	41,8	
	NEG 251800			142,8	97,0	17.620	17.235		-	1,1	1,2	2,0	1,9	49,3	45,3
	NEG 252060			163	112,4	20.113	19.971		-	1,35	1,45	2,5	2,3	54	52
	NEG 252370	160	AL	192,4	134,8	23.740	23.951	T3, T4	1,6	1,7	3,2	3,0	75	69	
	NEG 253050			247,0	171,6	30.477	30.490		-	1,9	2,0	3,8	3,5	82	79
	NEG 253720	170	GGG	301,6	206,7	37.214	36.726	T3, T4	2,2	2,5	3,9	3,9	127	122	
	NEG 254310			349,2	234,7	43.088	41.702		-	2,5	2,8	4,8	4,65	125	120
	NEG 254900	180	GGG	396,8	272,8	48.961	48.472	T3	3,6	3,4	6,0	5,0	174	166	
	NEG 256460	190	GGG	523,8	364,6	64.632	64.783	-	6,0	6,0	10,5	9,0	212	200	
	NEG 258040	195	GGG	652,0	452,0	80.450	80.312	-	7,0	8,0	11,6	11,5	225	210	
	NEG 258260	197	GGG	669,2	492,4	82.573	87.490	-	7,5	8,5	12,2	12,0	317	303	
	NEG 2511210	200	GGG	908,8	633,2	112.137	112.508	-	10,0	10,5	17,5	15,5	433	411	
	NEG 2513850			1.122,8	825,2	138.542	145.981		-	11,0	12,0	20,0	20,0	458	424
	NEG 16810	140	AL	144,2	111,8	7.908	8.829	T3, T4	0,68	0,76	1,4	1,4	46	41	
	NEG 161130			202,0	142,8	11.078	11.277		-	0,75	0,75	1,7	1,5	57	48
NEG 161420	254,2			187,4	13.940	14.799	-		0,95	1,0	1,8	1,7	65	58	
NEG 161610	160	AL	292,8	192,4	16.057	15.194	T3, T4	1,1	1,3	2,2	2,2	80	76		
NEG 162110			385,4	263,6	21.135	20.816		-	1,5	1,77	3,0	2,8	95	83	
NEG 162550	170	GGG	464,2	323,0	25.457	25.507	T3	1,96	2,1	4,1	3,75	140	127		
NEG 163030			553,4	400,0	30.348	31.588		-	2,2	2,4	4,5	4,3	156	141	
NEG 163820	180	GGG	696,4	467,4	38.191	38.253	T3, T4	2,5	3,0	5,1	5,0	200	182		
NEG 164700			857,0	587,4	46.998	46.387		-	3,2	3,6	6,5	6,0	219	198	
NEG 165190	190	GGG	946,4	658,4	51.901	51.994	T3	3,8	4,0	7,0	6,5	247	225		
NEG 166270			1.142,8	795,0	62.671	62.781		-	4,3	5,0	8,2	8,1	279	251	
NEG 166670	197	GGG	1.216,6	795,8	66.718	62.844	-	5,0	5,9	10,0	9,8	285	257		
NEG 167890			1.439,4	993,4	78.937	78.448		-	7,0	7,5	9,6	13,0	320	282	
NEG 168500	195	GGG	1.550,4	1.077,0	85.024	85.050	-	7,5	8,2	14,0	12,9	326	289		
NEG 169510	197	GGG	1.734,6	1.132,8	95.125	89.457	-	7,6	8,0	13,5	12,4	381	340		
NEG 1612060	200	GGG	2.199,2	1.508,6	120.604	119.134	-	9,0	9,5	16,3	15,0	500	445		
NEG 1613890	205	GGG	2.532,4	1.740,0	138.877	137.407	-	10,6	11,3	19,0	18,0	643	605		
NEG 1617000			3.100,0	2.087,8	170.004	164.873		-	13,0	13,7	24,5	23,0	705	656	
NEG 12460	140	AL	144,4	142,2	4.454	6.317	T3	-	0,45	1,2	1,2	46	46		
NEG 12640			202,0	195,6	6.231	8.689		T3, T4	0,4	0,5	1,4	1,3	57	57	
NEG 12900	160	AL	292,8	292,8	9.032	13.006	T3	0,95	1,1	2,2	2,2	80	80		
NEG 121430	170	GGG	464,2	464,2	14.319	20.620	T3	1,5	1,79	4,1	4,2	133	133		
NEG 122150	180	GGG	696,4	696,4	21.482	30.934	T3	2,0	2,3	5,4	5,2	201	201		
NEG 122640			857,0	857,0	26.436	38.068		-	2,5	3,0	6,0	6,0	217	217	
NEG 122920	190	GGG	964,4	964,4	29.194	42.839	T3	2,8	3,35	6,5	6,5	242	242		
NEG 123530			1.142,8	1.142,8	35.253	50.764		T3	4,0	4,3	8,2	7,85	267	267	
NEG 124440	195	GGG	1.439,4	1.439,4	44.402	63.939	-	4,9	5,8	9,9	9,5	320	320		
NEG 127640	197	GGG	2.478,0	2.194,6	76.440	97.485	-	6,8	7,5	13,2	12,0	438	419		
NEG 128520	200	GGG	2.763,2	2.481,4	85.238	110.225	-	7,6	8,3	14,0	13,5	540	520		
NEG 1211070	205	GGG	3.589,2	3.100,0	110.718	137.703	-	9,2	9,6	21,0	19,5	702	680		
NEG 1213160			4.267,4	3.812,8	131.639	169.366		-	10,4	11,2	22,0	20,0	755	711	
NEG 1217670	210	GGG	5.726,6	4.901,6	176.651	217.731	-	12,5	16,2	26,5	28,0	1.015	981		

*Technical data available upon request

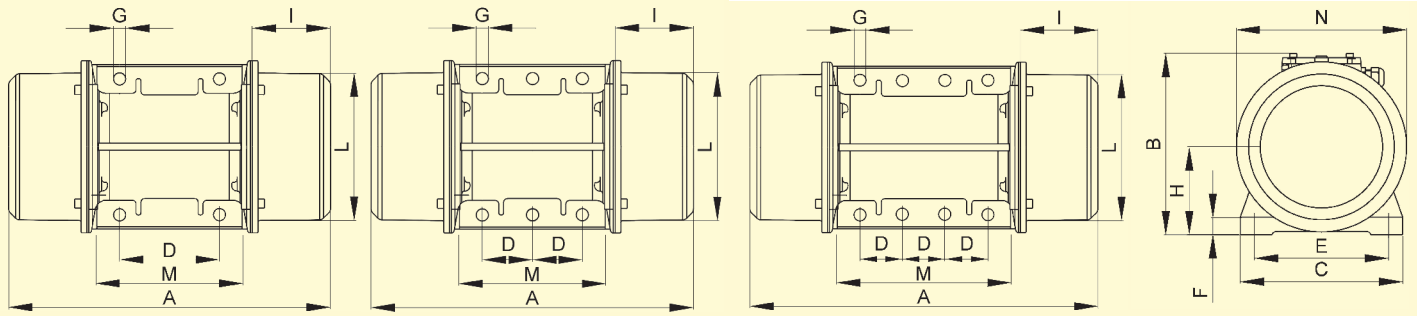

Type	Type of Housing	Dimensions [mm]													Unbalance [No. of Unbalance Discs]	
		A 50/60 Hz	B	C	D	E	n ₂ Mounting Pattern	F	G	H	I 50/60 Hz	L	M	N	Typ	50/60 Hz
NEG 501540	IV	438	257	230	140	190	4	25	17	124,5	103	201	224	241	XLs	12/8
NEG 501800																14/10
NEG 502020	IV	463	235	230	140	190	4	22	17	104	104	188	248	224	XLs	16/10
NEG 502270																18/12
NEG 503400	IV	590	335	310	155	255	4	30	23,5	160	140	274	302	310	XLs	12/8
NEG 503820																14/10
NEG 506220	IV	670	380	390	200	320	4	32	28	189	155	340	360	384	XS	4
NEG 508830	IV	629	395	392	200	320	4	100	28	192	134,5	358	270	375	XS	4
NEG 251410	IV	438	257	230	140	190	4	25	17	124,5	103	201	224	241	XS	4
NEG 251800		490									129					
NEG 252060		560									164					
NEG 252370	IV	523	283	275	155	225	4	28	22	140	130	231	255	271	XS	4
NEG 253050		600									168,5					
NEG 253720	IV	588	335	310	155	255	4	30	23,5	160	139	274	302	310	XS	4
NEG 254310		670/588									180/139					
NEG 254900	IV	640	369	340	180	280	4	30	26	173	155	301	322	336	XS	4
NEG 256460	IV	670	380	390	200	320	4	32	28	189	155	340	360	384	XS	4
NEG 258040	IV	624	402	392	200	320	4	35	28	199,5	132	358	352	402	XS	4
NEG 258260	IV	862	434,5	460	125	380	6	35	38	215	230	379	392	439	XS	4
NEG 2511210	IV	990	454	530	140	440	6	38	44	230	240	423	510	448	XS	4
NEG 2513850																
NEG 16810	IV	490/438	257	230	140	190	4	25	17	124,5	129/103	201	224	241	XS	4
NEG 161130		560									164					
NEG 161420																
NEG 161610	IV	600/523	283	275	155	225	4	28	22	140	168,5/130	231	255	271	XS	4
NEG 162110		655/600									196/168,5					
NEG 162550	IV	670/610	335	310	155	255	4	30	23,5	160	180/150	274	302	310	XS	4
NEG 163030		710									200					
NEG 163820	IV	742	369	340	180	280	4	30	26	173	206	301	322	336	XS	4
NEG 164700		802									236					
NEG 165190	IV	772	380	390	200	320	4	32	28	189	206	340	360	384	XS	4
NEG 166270		850									245					
NEG 166670	IV	750	434,5	460	125	380	6	35	39	215	174	379	392	439	XS	4
NEG 167890	IV	854	402	392	200	320	4	35	28	199,5	247	358	352	402	XS	4
NEG 168500																
NEG 169510	IV	862	434,5	460	125	380	6	35	39	215	230	379	392	439	XS	4
NEG 1612060	IV	990	454	530	140	440	6	38	44	230	240	423	510	448	XS	4
NEG 1613890	IV	960	526	570	140	480	8	41	45	268	200	488	560	516	XS	4
NEG 1617000		1.040									240					
NEG 12460	IV	490	257	230	140	190	4	25	17	124,5	129	201	224	241	XS	4
NEG 12640		560									164					
NEG 12900	IV	600	283	275	155	225	4	28	22	140	168,5	231	255	271	XS	4
NEG 121430	IV	670	335	310	155	255	4	30	23,5	160	180	274	302	310	XS	4
NEG 122150	IV	742	369	340	180	280	4	30	26	173	206	301	322	336	XS	4
NEG 122640		802									236					
NEG 122920	IV	772	380	390	200	320	4	32	28	189	206	340	360	384	XS	4
NEG 123530		850									245					
NEG 124440	IV	854	402	392	200	320	4	35	28	199,5	247	358	352	402	XS	4
NEG 127640	IV	1.002	434,5	460	125	380	6	35	39	215	300	379	392	439	XS	4
NEG 128520	IV	1.070	454	530	140	440	6	38	44	230	280	423	510	448	XS	4
NEG 1211070	IV	1.040	526	570	140	480	8	41	45	268	240	488	560	516	XS	4
NEG 1213160		1.120									280					
NEG 1217670	IV	1.150	607	610	140	520	8	38	45	297	280	542	510	582	XS	4



Netter Electric External Vibrators Series NEG

Special Version with Reduced Duty Time

Applications

Series NEG electric external vibrators are designed for continuous operation with 100% duty time. In addition, special versions with reduced duty times are available. The reduced duty time allows the use of smaller units possible with the same power output.

Design and functioning principle

Special vibrators with larger unbalances can be used for intermittent or short-time operation. Despite smaller unit size they deliver the same centrifugal forces as the next housing size up.

NEG with reduced duty times are built according to the customer's requirements, to enable individual solutions.

Special Version with CC Unbalances

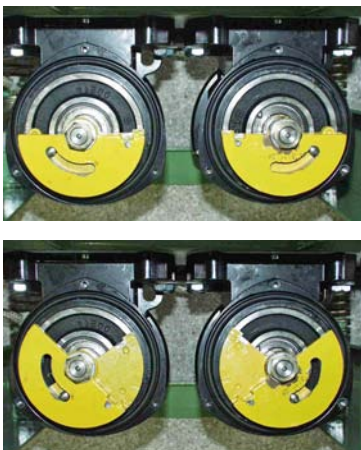

Applications

The special version with CC unbalances are used when two different unbalance settings need to be available during operation.

Design and functioning principle

In order to use the CC unbalances, a suitable electric switching circuit is required so that the NEG can be operated in both directions. When the NEG rotates in one direction it operates with e.g. maximum unbalance (top picture).

When the direction of rotation changes, the outer unbalance disc automatically turns through a specified angle against the inner unbalance disc, creating a reduced unbalance setting (picture below).

The CC unbalances are built according to the customer's requirements and allow a second unbalance setting of 25-100% of the main value.

Special Version NEG S in Stainless Steel



Applications

Series NEG S electric external vibrators can be used wherever the surfaces are subject to particular requirements for chemical resistance. An important feature of the NEG S series is its modular construction. This enables economical production of even the smallest of series in various steel materials. The protection class IP 66 (protection from dust entry and water flooding) allows cleaning with power jets and aggressive cleaning agents.

Design and functioning principle

All internal components of the stainless steel vibrators come from the established NEG series and are thus production proved.

Even the standard version of the NEG S has a surface quality of 6,3 µm and therefore satisfies the requirements for the chemical and pharmaceutical industries. A higher surface quality can easily be provided if required, e.g. for the food industry. Stainless steel housings are generally heavier than the standard housings. The greater mass must therefore be considered in the layout stage.

Static Adjustable Frequency Converter Series NFI/NFU Static Adjustable Frequency Control Series SRF

Applications

The frequency control of the series SRF and the frequency converters of the series NFI and NFU are used for speed regulation of electric vibrators.

Special applications require frequencies which cannot be achieved with normal multipole vibrators at line frequency. These frequency converters are characterized by their robust and straight-forward design.

Design and Functioning Principle

Low-loss power electronics permit the operation at input voltages with high tolerances. The frequency converters generate three-phase voltages with variable frequencies of 0 Hz to 500 Hz, thus making it possible to easily adjust the speed. The permissible temperature range is 0°C to +40°C.

All required parameters such as starting and stopping time, run-up ramp, maximum motor and pulse frequency, slip compensation and U/F characteristic are predefined by **NetterVibration**.

Optionally a brake resistor can be used for time-critical applications or large vibrators which permits a rapid braking / deceleration within a few revolutions after switching off the supply voltage in order to avoid unwanted resonance vibrations.



SRF frequency controls are mounted in a switch cabinet with protection type IP 54.



NFI frequency converters are mounted in an IP 2x housing for installation in a customer existing switch cabinet. The performance data correspond to those of the series SRF.



NFU frequency converters with motor output in the IP 54 housing for wall-mounting are equipped with an on-off switch, direction switch and set point potentiometer.

Type*	Supply Voltage	Max. Motor		Dimensions (W× H× D) [mm]
		Power Input [kW]	Current [A]	
SRF 1-007/4,8	1 ~ 200 ... 240 V 50/60 HZ	0,75	4,8	300 × 400 × 200
SRF 1-011/6,9		1,10	6,9	300 × 400 × 200
SRF 1-022/11		2,20	11,0	400 × 500 × 250
SRF 2-007/2,3	3 ~ 380 ... 415 V 50/60 HZ	0,75	2,3	400 × 500 × 250
SRF 2-015/4,1		1,50	4,1	
SRF 2-022/5,5		2,20	5,5	
SRF 2-040/9,5		4,00	9,5	
SRF 2-055/14,3		5,50	14,3	600 × 600 × 300
SRF 2-075/17		7,50	17,0	
SRF 2-110/27,7		11,00	27,7	
SRF 2-150/33	15,00	33,0		

* Technical data apply also to NFI

Type	Supply Voltage	Max. Motor-Current		Dimensions (W× H× D) [mm]
		Power Input [kW]	Current [A]	
NFU 1-004/3,3	1 ~ 200 ... 240 V 50/60 HZ	0,4	3,3	210 × 240 × 163
NFU 1-007/4,8		0,75	4,8	215 × 297 × 192
NFU 1-011/6,9		1,1	6,9	
NFU 1-015/8		1,5	8,0	
NFU 1-022/11		2,2	11,0	230 × 340 × 208
NFU 2-004/1,5	3 ~ 380 ... 415 V 50/60 HZ	0,4	1,5	215 × 297 × 192
NFU 2-007/2,3		0,75	2,3	
NFU 2-011/3		1,1	3,0	
NFU 2-015/4,1		1,5	4,1	230 × 340 × 208
NFU 2-022/5,5		2,2	5,5	
NFU 2-040/9,5		4,0	9,5	

Netter Braking Devices Series BZ



Type	Supply Voltage	Max. Nominal Power [kW]	Dimensions (W x H x D) [mm]
BZ 30	1 ~ 230 V /	5 / 5,5	55 × 68 × 110
BZ 70	3 – 400 V	10 / 11	158 × 185 × 110
BZ 200	50/60 Hz	26 / 28	145 × 270 × 180

The max. nominal power serves only as a guide for selection. Please consult us, we will help you with your layout!

Applications

Series BZ braking devices are used to bring the running NEG to a standstill as quickly as possible.

It is often necessary to be able to switch off vibrating tables and conveyors without them running on, in order to avoid the symptoms of resonance.

A special feature of these devices is a very high braking efficiency with compact unit size.

Design and functioning principle

Upon activation of the brake the load-resistant power electronics changes the direction of the electric rotational field, thus bringing the NEG to an immediate standstill. The momentarily high braking currents are easily tolerated by the NEG. The permissible temperature range lies between 0°C and +40°C.

These braking devices are only suitable for constant mains frequencies of 50 Hz or 60 Hz. Operation together with a frequency converter is not permitted.



Netter Electric External Vibrators Series NEG

Formulas

Unbalance	$M = s \times m$	Centrifugal force	$F = a_{(g)} \times m \times 9,81$
Acceleration	$a_{(g)} = s \times \left(\frac{n}{1000}\right)^2 \times 5,59$	Centrifugal force	$F = M \times \left(\frac{n}{1000}\right)^2 \times 54,84$

Symbols and Units

s	Amplitude	cm	n	Frequency	min ⁻¹
m	Weight with vibrator	kg	M	Unbalance	cmkg
F	Centrifugal force	N	a _(g)	Acceleration	g

Which Kind of Vibrator for Which Kind of Duty?

Duty	Frequency	Acceleration [a _(g)] Times acceleration due to gravity	Amplitude	Vibration	
				Rotary	Linear
Conveying, dosing	750 – 3000	2 – 5	Large		↔
Sieving	1000 – 1500	3 – 4	Large		↔
Draining	1500 – 3000	3 – 5	Medium		↔
Cleaning, shaking off filters	1500 – 3000	2 – 3	Medium		↻
Lightening, loosening Emptying bulk material	1500 – 3000	0.15 - 0.2 of weight of material in the conical part of the silo	Medium		↻
Compacting bulk material	1500 – 6000	2 – 4	Small	↻	↔
Concrete compaction	3000 – 9000	0,8 – 1,5	Very small	↻	↔
Testing components	300 – 6600	0,5 – 5	Adjustable	↻	↔



Conveying



Sieving



Compacting

Applications

Series NEG, NEA or NED electric external vibrators are used whenever, for example, conveyor chutes or sieves need to be driven. In addition, these devices can loosen material blockages and adhesions in silos. When used on concrete forms, the especially even vibration produces high surface quality and compaction of the concrete.

The special feature of the NEG is its maintenance-free operation, even in rough environmental conditions.

Design and functioning principle

Electric external vibrators are unbalance motors, which work according to the short circuit runner principle and, apart from a few significant differences, are very similar to conventional electric motors.

The 3-phase NEG units run at 750, 1000 or 3000 min⁻¹ with a 230/400V, 50 Hz power supply, depending on the number of poles.

The NEA single phase units run at 3000 min⁻¹ with a 230V, 50 Hz power supply. Additional voltages are available.

The direct current NED units run at 3000 min⁻¹ with a 12 or 24 Volt power supply.

Unbalances sitting on each end of the shaft produce an unidirectional sinus-shaped rotation at the frequency of the respective speed of rotation.

All NEG/NEA are also designed for operation at 60 Hz. The speed of rotation then lies at 20% above the values at 50 Hz. The unbalance is adjusted if necessary.

Generously dimensioned rolling bearings guarantee high operational safety. All NEG are suitable for operation with Netter frequency converters, without limitation.

**Netter provides solutions.
Consult our experienced application technicians.**

Netter GmbH

Germany
Fritz-Ullmann-Str. 9
55252 Mainz-Kastel
Tel. +49 6134 2901-0
Fax +49 6134 2901-33

Switzerland

Erlenweg 4
4310 Rheinfelden
Tel. +41 61 8316200
Fax +41 61 8311291

Poland

Al. W. Korfantego 195/17
40-153 Katowice
Tel. +48 32 2050947
Fax +48 32 2051572

www.**NetterVibration.com**
info@**NetterVibration.com**



9

Netter Stainless Steel Electric External Vibrators Series NES



- Circular vibration
- Especially resistant to aggressive environmental conditions
- Centrifugal force from 296 N to 42.446 N
- High operational safety
- Tropical insulation by vacuum impregnation
- Protection IP 66
- Nominal frequency from 750 min⁻¹ to 3.600 min⁻¹
- Stainless steel housing
- Ex II 2 D (ATEX) versions available





NetterVibration



Netter Stainless Steel Electric External Vibrators Series NES

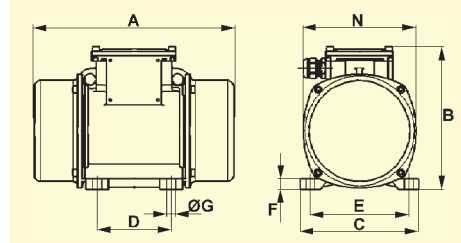

[min ⁻¹]	Type	Working Moment [cmkg]		Centrifugal Force [N]		Power [kW]		Current [A]		Weight [kg]		Dimensions [mm]						
		50 Hz	60 Hz	50 Hz	60 Hz	50 Hz	60 Hz	50 Hz 400 V	60 Hz 480 V	50 Hz	60 Hz	A 50/60 Hz	B	C	D	E	F	G
3000 3600	NES 50120	2,40	2,40	1.185	1.706	0,180	0,180	0,35	0,30	7,80	7,80	209	151	125	62-74	106	10	9
	NES 50210	4,20	3,00	2.073	2.133	0,180	0,180	0,35	0,30	8,20	8,00	225	151	125	62-74	106	10	9
	NES 50300	6,02	4,08	2.972	2.900	0,260	0,270	0,60	0,50	12,50	12,00	255	176	152	90	125	12	13
	NES 50500	9,97	6,48	4.921	4.606	0,450	0,500	0,80	0,75	18,50	17,50	284	200	167	105	140	15	13
	NES 50790	15,59	10,40	7.695	7.392	0,650	0,685	1,10	1,00	25,00	24,00	308	205	205	120	170	17	17
	NES 501090	22,00	14,60	10.858	10.377	1,000	1,200	1,75	1,75	30,00	29,00	354	232	205	120	170	20	17
	NES 501510	30,60	20,40	15.103	14.499	1,400	1,450	2,30	2,00	39,60	38,00	438	245	230	140	190	25	17
	NES 502020	41,00	25,60	20.236	18.195	2,200	2,200	3,50	3,00	48,70	46,30	438	245	230	140	190	25	17
1500 1800	NES 2530	2,40	2,40	296	426	0,085	0,095	0,21	0,20	7,80	7,80	209	151	125	62-74	106	10	9
	NES 2580	6,20	4,20	766	747	0,085	0,095	0,21	0,20	9,00	8,70	225	151	125	62-74	106	10	9
	NES 25100	7,78	6,20	960	1.102	0,085	0,095	0,21	0,20	9,40	9,00	241/225	151	125	62-74	106	10	9
	NES 25210	16,84	11,76	2.078	2.090	0,170	0,170	0,41	0,40	15,80	15,00	295	176	152	90	125	12	13
	NES 25410	32,64	22,66	4.028	4.027	0,300	0,350	0,60	0,60	22,50	21,70	340	200	167	105	140	15	13
	NES 25550	43,80	32,64	5.405	5.800	0,300	0,350	0,60	0,60	23,90	22,50	380	200	167	105	140	15	13
	NES 25720	57,18	41,89	7.056	7.444	0,525	0,665	0,92	0,98	32,00	30,70	378	211	205	120	170	17	17
	NES 251030	83,00	54,20	10.241	9.630	0,550	0,680	0,95	0,95	42,00	37,50	434	232	205	120	170	20	17
	NES 251390	112,20	80,00	13.844	14.215	0,900	1,050	1,45	1,50	53,00	50,00	442	245	230	140	190	25	17
	NES 251760	143,00	97,00	17.645	17.235	1,100	1,200	2,00	1,90	58,50	54,50	490	245	230	140	190	25	17
	NES 252020	163,40	112,20	20.162	19.936	1,350	1,450	2,50	2,30	70,00	68,00	560	245	230	140	190	25	17
	NES 252380	192,40	134,80	23.740	23.951	1,600	1,700	3,20	3,00	82,00	76,00	525	285	275	155	225	30	22
	NES 253050	247,00	171,60	30.477	30.490	1,900	2,000	3,80	3,50	92,00	89,00	601	285	275	155	255	30	22
	NES 253770	305,20	206,80	37.659	36.745	2,200	2,500	3,90	3,90	115,00	110,00	589	323	310	155	255	35	23,5
NES 244250	344,00	234,60	42.446	41.684	2,500	2,800	4,80	4,65	122,00	117,00	589	323	310	155	255	35	23,5	
1000 1200	NES 1630	6,02	6,02	331	476	0,120	0,135	0,30	0,30	12,50	12,50	255	176	152	90	125	12	13
	NES 16100	16,84	16,84	924	1.330	0,120	0,135	0,30	0,30	15,80	15,80	295	176	152	90	125	12	13
	NES 16190	32,64	32,64	1.790	2.578	0,185	0,205	0,50	0,50	22,50	22,50	340	200	167	105	140	15	13
	NES 16320	57,18	41,89	3.136	3.309	0,350	0,380	0,72	0,68	32,00	30,70	378	211	205	120	170	17	17
	NES 16500	91,40	91,40	5.012	7.218	0,350	0,380	0,75	0,68	43,50	43,50	434	232	205	120	170	20	17
	NES 16800	144,60	112,20	7.930	8.860	0,680	0,760	1,40	1,35	54,00	52,60	490/442	245	230	140	190	25	17
	NES 161110	202,40	143,00	11.100	11.293	0,750	0,750	1,65	1,50	67,00	59,50	560/490	245	230	140	190	25	17
	NES 161400	254,80	180,80	13.973	14.278	0,950	1,000	2,10	2,00	78,00	71,00	560	245	230	140	190	25	17
	NES 161610	292,80	192,40	16.057	15.194	1,100	1,300	2,20	2,20	94,00	83,00	601/525	285	275	155	225	30	22
	NES 162120	385,40	263,60	21.135	20.816	1,500	1,700	3,00	2,90	105,00	93,00	601	285	275	155	225	30	22
750 900	NES 162550	465,20	341,20	25.512	26.944	1,960	2,100	4,10	3,75	130,00	116,00	657/589	323	310	155	255	35	23,5
	NES 162950	538,00	388,00	29.504	30.640	2,200	2,400	4,50	4,30	145,00	130,00	705	323	310	155	255	35	23,5
	NES 12100	32,64	32,64	1.007	1.450	0,230	0,250	0,85	0,76	22,50	22,50	340	200	167	105	140	15	13
	NES 12180	56,80	56,80	1.752	2.523	0,350	0,380	1,10	1,05	32,00	32,00	378	211	205	120	170	17	17

Applications

The stainless steel electric vibrators of the NES series are used mainly in the chemical, pharmaceutical and food industries. They serve as drives for conveyor troughs, sieves and discharge devices.

The stainless steel surfaces of the vibrators are especially resistant to chemically corrosive environmental conditions and can be thoroughly cleaned manually and by machine with powerful cleaning agents.

Construction and Working Principle

Stainless steel electric external vibrators are three-phase current asynchronous motors with adjustable unbalances at both ends of the shaft. These unbalances generate an undirected sinusoidal vibration with the frequency of the corresponding rotation speed.

The extremely load-resistant roller bearings guarantee a long working life. All NES are suitable for operation with Netter frequency and voltage converters.

NetterVibration has a worldwide network of experienced application engineers and field representatives. We would be pleased to offer advice on site and to help optimise your applications using vibration technology.

NetterVibration offers the accessories required for the mounting, installation, control and monitoring of vibrators and impactors.

Netter provides solutions. Consult our experienced application technicians.

Netter GmbH

Germany
Fritz-Ullmann-Str. 9
55252 Mainz-Kastel
Tel. +49 6134 2901-0
Fax +49 6134 2901-33

Switzerland
Erlenweg 4
4310 Rheinfelden
Tel. +41 61 8316200
Fax +41 61 8311291

Poland
Al. W. Korfantego 195/17
40-153 Katowice
Tel. +48 32 2050947
Fax +48 32 2051572

www.**NetterVibration.com**
info@**NetterVibration.com**

06/2012 Subject to change without notice



36

Netter Static Adjustable Frequency Controls Series SRF / NFI / NFU

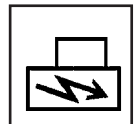

- Infinitely adjustable speed control of electric external and internal vibrators
- Parallel connection of multiple vibrators
- Simple and robust design
- Clearly arranged menu navigation
- Special versions according to customer





NetterVibration



Netter Static Adjustable Frequency Controls Series SRF



Type	Supply Voltage	Max. Motor-		Dimensions (W x H x D) [mm]
		Power Input [kW]	Current [A]	
SRF 1-007/4,8	1~ 200..240V 50/60Hz	0,75	4,8	300 x 400 x 200
SRF 1-011/6,9		1,10	6,9	
SRF 1-022/11		2,20	11,0	
SRF 2-007/2,3	3~ 380..415V 50/60Hz	0,75	2,3	400 x 500 x 250
SRF 2-015/4,1		1,50	4,1	
SRF 2-022/5,5		2,20	5,5	
SRF 2-040/9,5		4,00	9,5	
SRF 2-055/14,3		5,50	14,3	
SRF 2-075/17		7,50	17,0	
SRF 2-110/27,7		11,00	27,7	
SRF 2-150/33	15,00	33,0	600 x 600 x 300	



Switch Cabinet

As a standard, the frequency control systems of the series SRF are mounted in switch cabinets. These switch cabinets are suitable for wall mounting and provide protection against dust and splash water (Protection type IP54). Netter SRF are also available as switch cabinet with socket, with frame and as desk version.

The standard color is light grey. (RAL 7035), other colors or a stainless steel enclosure are available. The motor outputs are connected to a terminal strip or, if requested by the customer, the housing of the switch cabinet is provided with plug connections.

The dimensions of the switch cabinet depend on the size of the frequency converter.



Operation

As a standard, the SRF can be operated and controlled using a 3.5" color touch panel.

The vibration process can be started and stopped by this panel. By buttons or a keyboard the operator can enter the desired frequency and shaking time, readable on large displays. As languages G/E/F can be selected.

The CC unbalance function (big/small working moment) and a control group for two vibrating tables are stored in the program and can be activated if required. Error messages and alarms are displayed in separate windows which simplifies maintenance and service. Depending on the customer's requests, the size of the touch panel and the program of the SRF can be adjusted to suit the requirements on site.

Configuration

If requested, **NetterVibration** can configure additional inputs and outputs on the SRF, therewith safety devices or external operating units can be connected

to the SRF. An optional mini control system allows complex monitoring and control tasks.

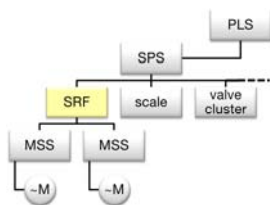

Bus Communication

Netter SRF can be used for all kinds of communication configurations in industrial plants.

The communication via Modbus, CANopen and other bus systems is possible after consultation with **NetterVibration**.

When the SRF is integrated into an existing production process, it communicates with the central process control system.



Avoiding Uncontrolled Resonances

The integrated braking function in the frequency converter helps to prevent uncontrolled oscillation when decelerating the vibrators. This might have a negative effect on the vibration result.

Depending on the application and for the control of multipole vibrators with high working moments we recommend the use of separate brake resistors.

Netter Static Adjustable Frequency Converter Series NFI



Type	Supply Voltage	Max. Motor-		Dimensions (W x H x D) [mm]
		Power Input [kW]	Current [A]	
NFI 1-007/4,8	1~ 200..240V 50/60Hz	0,75	4,8	72 x 145 x 142
NFI 1-011/6,9		1,10	6,9	107 x 143 x 132
NFI 1-022/11		2,20	11,0	142 x 184 x 152
NFI 2-007/2,3	3~ 380..415V 50/60Hz	0,75	2,3	107 x 143 x 132
NFI 2-015/4,1		1,50	4,1	142 x 184 x 152
NFI 2-022/5,5		2,20	5,5	
NFI 2-040/9,5		4,00	9,5	
NFI 2-055/14,3		5,50	14,3	180 x 210 x 172
NFI 2-075/17		7,50	17,0	
NFI 2-110/27,7		11,00	27,7	
NFI 2-150/33		15,00	33,0	245 x 295 x 192

NFI frequency converters are mounted in an IP 2x housing for installation in a customer's existing switch cabinet. The performance data correspond to those of the series SRF.

Netter Static Adjustable Frequency Converter Series NFU



Type	Supply Voltage	Max. Motor-		Dimensions (W x H x D) [mm]
		Power Input [kW]	Current [A]	
NFU 1-004/3,3	1~ 200..240V 50/60Hz	0,4	3,3	210 x 240 x 163
NFU 1-007/4,8		0,75	4,8	
NFU 1-011/6,9		1,1	6,9	215 x 297 x 192
NFU 1-015/8		1,5	8,0	
NFU 1-022/11		2,2	11,0	230 x 340 x 208
NFU 2-004/1,5	3~ 380..415V 50/60Hz	0,4	1,5	215 x 297 x 192
NFU 2-007/2,3		0,75	2,3	
NFU 2-011/3		1,1	3,0	
NFU 2-015/4,1		1,5	4,1	230 x 340 x 208
NFU 2-022/5,5		2,2	5,5	
NFU 2-040/9,5		4,0	9,5	

Netter frequency converters series NFU with motor output in the IP 54 housing for wall-mounting are equipped with an on-off switch, direction switch and potentiometer for frequency setting.

A display at the device shows the output frequency of the converter. The NFU can also communicate with other devices via Modbus or CANopen. The NFU offers the possibility to connect one vibrator. In case two or more vibrators are required, it is necessary to connect an external motor terminal box as well as a motor protection relay.

Optionally, a brake resistor can be mounted and connected to prevent uncontrolled vibrations in critical applications if required. The NFU is pre-adjusted and ready for installation.

Design

Depending on the application a reserve should be calculated when designing the frequency converter, as bigger vibrators have a higher starting current. If multi-pole vibrators (4 or 6-pole) are required, we recommend using Netter frequency converters with three-phase supply.



NetterVibration

Netter Static Adjustable Frequency Controls Special version of the series SRF

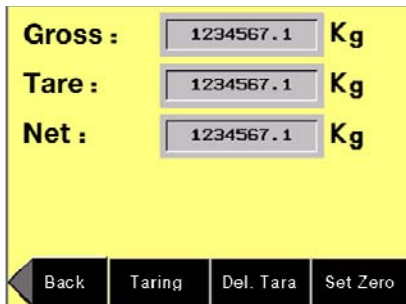

Integrated Weighing Mechanism

If required, **NetterVibration** offers the SRF with integrated weighing mechanism. It is possible to simultaneously compact and weigh bulk material by mounting weighing cells at the vibration table. The current weight is shown on the touch panel of the SRF. Also weight-dependent shaking applications are possible.

Pre-adjusted and ready for Installation

All required parameters, such as starting and stopping time, run-up ramp, maximum motor and pulse frequency, slip compensation and U/K characteristic will be pre-adjusted and tested depending on the application by **NetterVibration** before delivery.

After installation and connection at the customers' site the SRF is ready for operation.



Explosion-proof Control Systems

In dialogue with the user **NetterVibration** implements control systems which fulfil all requirements of the ATEX directive. These control systems comply with the Equipment Group II. Depending on the version it can be used in hazardous areas of the zones 1, 2, 21 or 22.



SRF with vibrating table



Integrated weighing system



SRF and vibrating table made of stainless steel



Vibrating table with roller track

Applications

The frequency control of the series SRF and the frequency converters of the series NFI and NFU are used for speed regulation of electric vibrators. Special applications require frequencies which cannot be achieved with normal vibrators at line frequency. These frequency converters are characterized by their simple and robust design.

Design and Functioning Principle

Low-loss power electronics allows the operation at input voltages with high tolerances. The frequency converters generate three-phase voltages with variable frequencies of 0 Hz to 500 Hz, what makes it possible to easily adjust the speed. The permissible temperature range is 0°C to +40°C.

All required parameters such as starting and stopping time, run-up ramp, maximum motor and pulse frequency, slip compensation and U/F characteristic are defined by **NetterVibration**.

Optionally a brake resistor can be used for time-critical applications. The brake resistor permits a fast braking within a few revolutions in order to avoid unwanted resonance vibrations.

NetterVibration offers the accessories required for the mounting, installation, control and monitoring of vibrators and impactors.

Netter provides solutions. Consult our experienced application technicians.

Netter GmbH

Germany

Fritz-Ullmann-Str. 9
55252 Mainz-Kastel
Tel. +49 6134 2901-0
Fax +49 6134 2901-33

Switzerland

Erlenweg 4
4310 Rheinfelden
Tel. +41 61 8316200
Fax +41 61 8311291

Poland

Al. W. Korfatego 195/17
40-153 Katowice
Tel. +48 32 2050947
Fax +48 32 2051572

www.**NetterVibration**.com
Info@**NetterVibration**.com



14

Netter Pneumatic External Vibrators Series NVR, NVG, NVT and NQT



- Circular vibration
- Nominal frequency from 8.500 min⁻¹ to 15.000 min⁻¹
- Centrifugal force from 7.130 N to 62.260 N
- Frequency infinitely variable by air pressure
- No bearings
- Easily and quickly removable
- Noise reduced design NQT



NVG 61



NVR 61



NVT with bracket NVH 4



NetterVibration



Netter Pneumatic External Vibrators Series NVR, NVG, NVT and NQT

Type		NVR [®] , NVG [®]			NVT [®] , NVG [®]		NVT [®] , NVG [®]			NQT	
		49	55	61	82	113	84	87	105	93	108
Nominal frequency	[min ⁻¹]	17.000	16.500	16.000	9.000	8.500	16.000	15.200	14.500	10.000	10.000
Centrifugal force	[N]	7.130	11.000	14.250	15.320	38.830	27.400	37.500	62.260	18.480	24.788
Unbalance	[cmkg]	0,45	0,74	1,02	3,45	9,80	1,95	2,96	5,40	3,37	4,52
Air consumption	[l/min]	1.000	1.100	1.200	1.600	1.700	1.600	1.600	1.800	1.450	1.550
Weight	[kg] ①	6,6	7,0	7,6	14,9	16,9	14,0	14,4	16,3		
without hose	[kg] ②	7,1	7,3	7,8	19,7	22,6	20,0	20,4	22,4		
Weight with hose	[kg]									18,6	20,3

NVG with base plate. NVT and NQT with carrying handle on top for bracket NVH 4. NVR without carrying handle for bracket NVH 1. Data obtained on 6 bar.

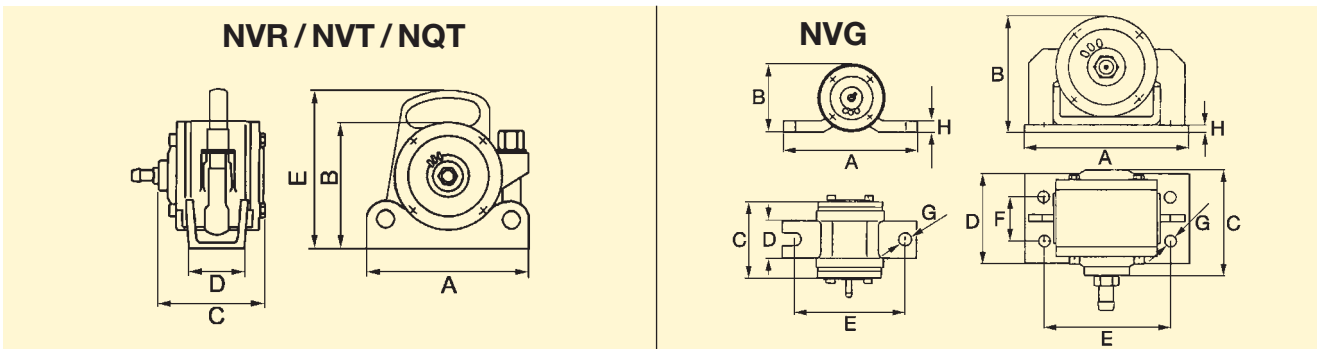

Type	A [mm]	B [mm]	C [mm]	D [mm]	E [mm]	F [mm]	Ø G [mm]	H [mm]
NVG 49, 55, 61	220	111	175	60	180	-	20	20
NVR 49, 55, 61	182	140	175	90	-	-	-	-
NVT 82, 113, 84, 87, 105	240	185	150	83	225	-	-	-
NVG 82, 113, 84, 87, 105	260	187	145	140	200	70	17	12
NQT 93, 108	240	230	240	80	-	-	-	-



Compacting of moulding sand



Tunnel moulds

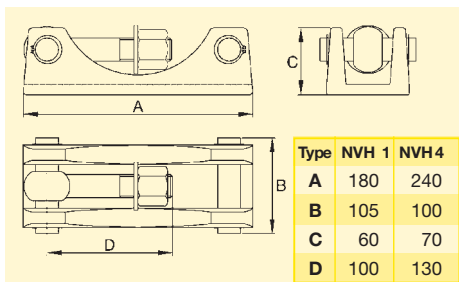

Dimensions of NVH 1 and NVH 4

Application

The pneumatic external vibrators series NQT, NVG, NVR und NVT are especially suitable for compacting, conveying and loosening bulk material.

They are used to compact concrete, empty bins and as drives for conveyors, sieves and vibrating tables.

A special feature is the ruggedness against strong varying loads.

There is no danger of overload.

Design and functioning principle

The vibration (circular) is produced by eccentric rotating rotors. The frequency and herewith the centrifugal force are continuously adjustable by the operating pressure. For operation a control valve is required (not included in scope of delivery).

Permissible operating conditions

Drive medium:

Compressed air or nitrogen (Filter ≤ 5 µm), preferably with oil mist.

Operating pressure:

1 bar to 7 bar

Ambient temperature:

-10°C to +60°C

Units for other temperatures are available.

NetterVibration offers the accessories required for the mounting, installation, control and monitoring of vibrators and impactors.

Netter provides solutions.

Consult our experienced application technicians.

Netter GmbH

Germany

Fritz-Ullmann-Str. 9
55252 Mainz-Kastel
Tel. +49 6134 2901-0
Fax +49 6134 2901-33

Switzerland

Erlenweg 4
4310 Rheinfelden
Tel. +41 61 8316200
Fax +41 61 8311291

Poland

Al. W. Korfantego 195/17
40-153 Katowice
Tel. +48 32 2050947
Fax +48 32 2051572

www.NetterVibration.com
info@NetterVibration.com



15

Netter Vacuum Fixing Devices for Vibrators Series VAC



- Quick mounting without bolting or welding
- Strong connection due to high vacuum
- Can also be used on curved or uneven surfaces
- Optional air economizer
- ATEX conform and stainless steel versions available
- Customized versions possible



VAC 10 with NCT 4



VAC 15 with PKL 740 ST



VAC 30 with NTS 50/04



Netter Vacuum Fixing Devices for Pneumatic Vibrators Series VAC

Type	Air consumption without vibration [l/min]		Weight [kg]	Minimum diameter for round containers [mm]	Suitable vibrators						
	4 bar	6 bar			NCB	NCR	NCT	NTK	NTS	NTP	PKL
VAC 8 +HG 10 N	40	60	0,95	110	1, 2		1, 2	8 AL, 15 X 16, 18 AL	120 HF, 120NF* 180HF, 180NF*	25**	
VAC 8 +HG 10 S	20	22	1,20								
VAC 10+HG 10 N	40	60	1,05	110	1, 2, 3	3	3, 4	15X, 18AL	180HF, 180NF* 250HF, 250NF*	25**	190
VAC 10+HG 10 S	20	22	1,30								
VAC 11 +HG 10 N	40	60	1,25	110	3, 5	10	5, 10	18 AL	180HF, 180NF 250HF, 250 NF		190, 450**
VAC 11 +HG 10 S	20	22	1,50								
VAC 12+HG 15 N	60	122	2,85	350	10, 20	22	15, 29	25 AL	350HF, 350 NF 100/01, 75/01, 50/01**	32**	450** 740**
VAC 12+HG 15 S	29	36	3,20								
VAC 13+HG 15 N	110	170	4,20	850	10, 20	22	15, 29		75/01, 50/01	32**	740, 2100 5000
VAC 13+HG 15 S	41	52	4,55								
VAC 15+HG 15 N	110	170	3,40	650	10, 20	22	15, 29	18AL, 25	250HF, 250NF, 350HF, 350NF 75/01, 50/01, 70/02*	32, 48*	740
VAC 15+HG 15 S	41	52	3,75								
VAC 20+HG 15 N	110	170	7,25	850		57	55, 108*		70/02, 54/02, 50/04*	32, 48	
VAC 20+HG 15 S	41	52	7,60								
VAC 30+HG 30 N	110	170	11,50	1.500		120	126, 250		50/04, 50/08*		NVG 49, 55, 61 NVG 82, 84*
VAC 30+HG 30 S	49	60	12,00								
VAC 40+HG 40 N	220	340	20,00	1.500					50/08*, 50/10*		

The technical data are comparative values and can vary depending on the application. Additional data available upon request. Subject to technical changes. *Depending on application, please consult **NetterVibration**. **Adapter plate necessary, please include in order!

Type	Model	A [mm]	B [mm]	C [mm]	D [mm]	E [mm]	F [mm]	Type	Model	A [mm]	B [mm]	C [mm]	D [mm]	E [mm]	F [mm]
VAC 8	I	19	8	150	127	30	55	VAC 13	III	70	30	186	241	195	197
VAC 10	I	22	8	200	175	26,5	55	VAC 15	II	56	25	345	290	100	150
VAC 11	I	20	5,5	300	276	26	55	VAC 20	II	70	30	425	370	150	200
VAC 12	I	25	10	300	268	68	100	VAC 30	IV	70	30	396	339	426	370
								VAC 40	V	70	25	426	375,6	425	370

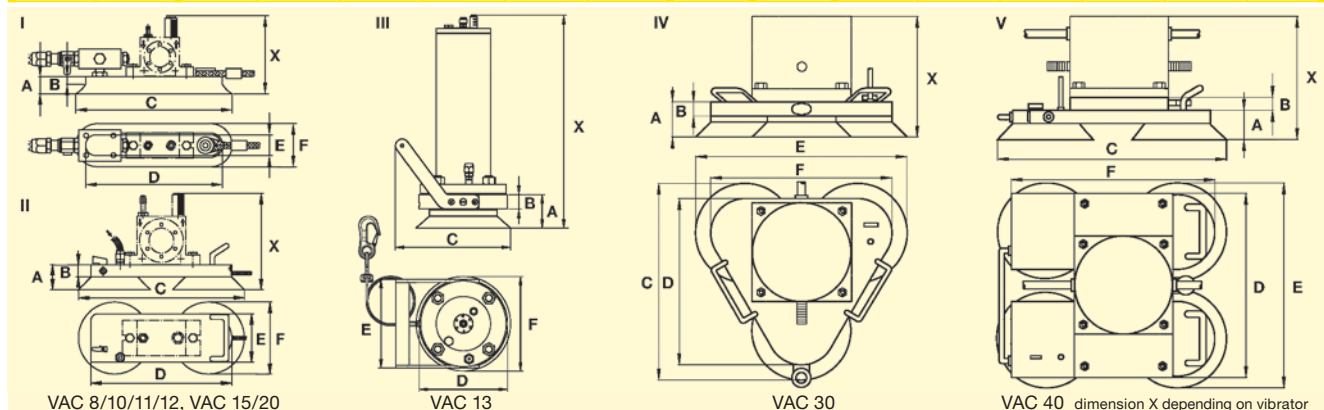

Application

The vacuum fixing devices VAC are designed to allow quick attachment of vibrators to smooth or, under circumstances, uneven and curved surfaces. A special feature of the vacuum fixing is the ease of attachment, which requires no welding or bolting.

Construction and working principle

The appropriate vibrator is screwed to the vacuum fixing and connected to the supply hose leading to the hand valve.

As soon as the vacuum fixing is connected to the compressed air supply, the unit is sucked tightly to the mounting surface, thus ensuring a strong connection between the vibrator and the surface.

The air economizer "S" creates a reduced vacuum, which is sufficient to clamp the vibrator when it is not running and which reduces the air consumption by over 30%.

ATEX conform vacuum fixings series VAC and units with stainless steel plate are available.

When the vibrator starts, the fixing device automatically produces the full vacuum.

Permissible operating conditions

Drive medium:

Compressed air or nitrogen (Filter ≤ 5 µm)

Operating pressure:

2 bar to 6 bar

Ambient temperature:

-10°C to 60°C

NetterVibration offers the accessories required for mounting, installation, control and monitoring of vibrators and impactors.

Netter provides solutions.

Consults our experienced application technicians.

Netter GmbH

Germany

Fritz-Ullmann-Str. 9
55252 Mainz-Kastel
Tel. +49 6134 2901-0
Fax +49 6134 2901-33

Switzerland

Erlenweg 4
4310 Rheinfelden
Tel. +41 61 8316200
Fax +41 61 8311291

Poland

Al. W. Korfanteo 195 / 17
40-153 Katowice
Tel. +48 32 2050947
Fax +48 32 2051572
info@**NetterVibration**.pl

www.**NetterVibration**.com
info@**NetterVibration**.com

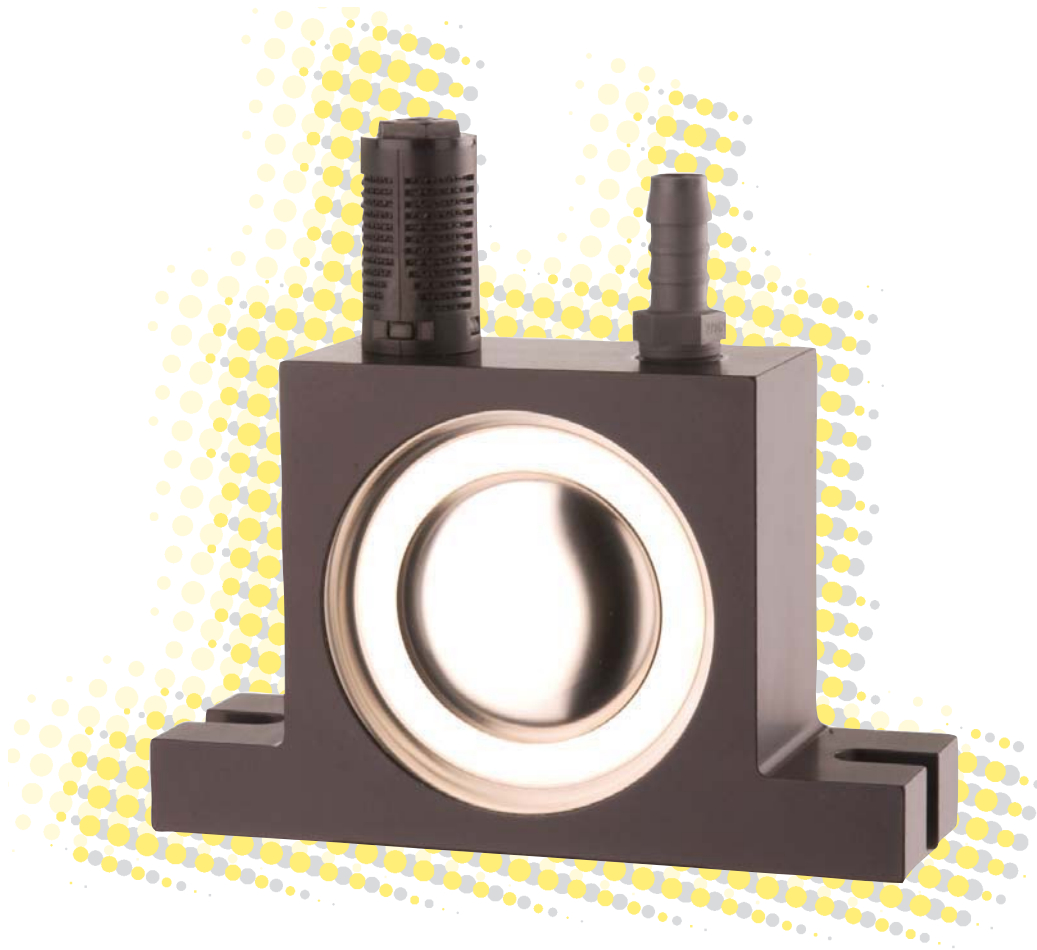

18

Netter Pneumatic Ball Vibrators Series NCB



- Rotary vibration
- Nominal frequency from 7.220 min⁻¹ to 42.340 min⁻¹
- Centrifugal force from 222 N to 4.866 N
- Frequency continuously adjustable via air pressure
- Suitable for temperatures up to 200°C



NCB 1



NCB 10

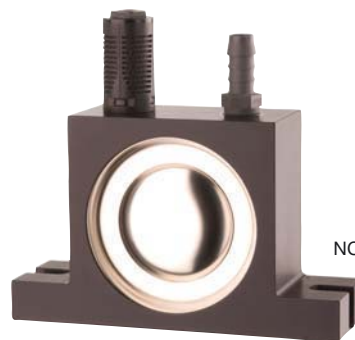

NCB 50



Netter Pneumatic Ball Vibrators Series NCB

Type	Working moment [cmkg]	Nominal frequency [min ⁻¹]			Centrifugal force [N]			Air consumption [l/min] 2 bar – 6 bar	Noise level* [dB(A)] 2 bar – 6 bar
		2 bar	4 bar	6 bar	2 bar	4 bar	6 bar		
NCB 1	0,005	28.460	37.060	42.340	222	377	491	38 – 112	71 – 79
NCB 2	0,009	22.880	31.160	37.540	258	479	696	38 – 115	74 – 79
NCB 3	0,029	17.100	21.600	24.360	465	742	947	81 – 219	74 – 82
NCB 5	0,046	15.220	19.180	22.480	587	933	1.277	77 – 217	78 – 85
NCB 10	0,131	11.320	14.380	16.380	921	1.486	1.928	226 – 463	82 – 89
NCB 20	0,211	10.560	13.780	15.420	1.298	2.198	2.753	222 – 468	78 – 86
NCB 50	0,522	7.220	9.940	11.220	1.492	2.828	3.603	312 – 733	80 – 86
NCB 70	0,808	7.220	8.820	10.480	2.310	3.446	4.866	310 – 728	75 – 84

*Specific silencer to reduce the noise level available.

Type	A [mm]	B [mm]	C [mm]	D [mm]	E [mm]	F	G* [mm]	H* [mm]	K [mm]	Weight [kg]
NCB 1	50	18	86	68	7	G 1/8	40	7	12	0,12
NCB 2	50	18	86	68	7	G 1/8	40	7	12	0,13
NCB 3	65	26	113	90	9	G 1/4	50	9	16	0,29
NCB 5	65	26	113	90	9	G 1/4	50	9	16	0,32
NCB 10	80	37	128	104	9	G 1/4	60	10	16	0,60
NCB 20	80	37	128	104	9	G 1/4	60	10	16	0,70
NCB 50	100	50	160	130	11	G 3/8	80	12	20	1,30
NCB 70	100	50	160	130	11	G 3/8	80	12	20	1,50

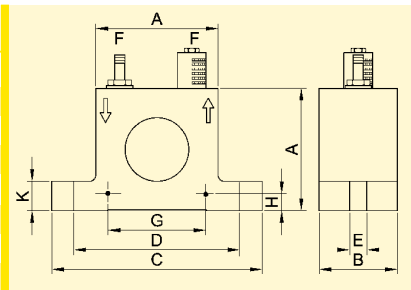

*Dimensions for horizontal mounting, bore ØE



Sorting and aligning



Emptying without bridging

Applications

Series NCB pneumatic ball vibrators can be used wherever bulk materials need to be moved.

They serve in the emptying of bunkers, for preventing bridging, rat-holing and adhesion. When used to drive chutes, sieves and vibrating tables, they ensure that the material flow is maintained.

The special feature is the simple construction.

Construction and Working Principle

The rotary vibration is created by the high centrifugal force produced by a circulating steel ball, which runs on hardened, polished steel races.

The frequency, and hence the centrifugal force, can be continuously regulated via the operating pressure.

Series NCB ball vibrators can be operated using lubrication-free compressed air.

A multi-directional valve is required for operation (not included in the scope of supply).

Permissible Operating Conditions

Drive medium:

Compressed air or nitrogen (filter ≤ 5 µm), preferably with oil mist

Operating pressure:

2 bar to 6 bar

Ambient temperature:

–20°C to +120°C

HT version up to +200°C

NetterVibration offers the accessories required for the mounting, installation, control and monitoring of vibrators and impactors.

Netter provides solutions.

Consult our experienced application technicians.

Netter GmbH

Germany

Fritz-Ullmann-Str. 9
55252 Mainz-Kastel
Tel. +49 6134 2901-0
Fax +49 6134 2901-33

Switzerland

Erlenweg 4
4310 Rheinfelden
Tel. +41 61 8316200
Fax +41 61 8311291

Poland

Al. W. Korfantego 195/17
40-153 Katowice
Tel. +48 32 2050947
Fax +48 32 2051572

www.NetterVibration.com
info@NetterVibration.com



20

Netter Pneumatic Roller Vibrators



Series NCR

- Rotary vibration
- Suitable for aggressive environmental conditions
- High propulsive power
- Nominal frequency from 10.140 min⁻¹ to 34.304 min⁻¹
- Centrifugal force from 878 N to 9.100 N
- Frequency continuously adjustable via air pressure
- Suitable for temperatures up to 200°C





Netter Pneumatic Roller Vibrators Series NCR

Type	Working moment [cmkg]	Nominal frequency [min ⁻¹]			Centrifugal force [N]			Air consumption [l/min]		Noise level [dB(A)]	
		2 bar	4 bar	6 bar	2 bar	4 bar	6 bar	2 bar	6 bar	2 bar	6 bar
NCR 3	0,031	22.699	30.480	34.304	878	1.579	2.000	55	146	74	85
NCR 10	0,102	20.180	24.520	27.760	2.278	3.363	4.311	121	301	74	86
NCR 22	0,224	16.400	20.040	21.780	3.313	4.933	5.828	162	424	77	87
NCR 57	0,572	12.480	14.370	15.465	4.902	6.489	7.520	246	574	74	91
NCR 120	1,200	10.140	11.680	11.760	6.765	8.976	9.100	315	768	86	97

The technical data are comparative values and can vary depending on application. Additional data available upon request.

Type	A [mm]	B [mm]	C [mm]	D [mm]	E [mm]	F	G* [mm]	H* [mm]	K [mm]	Weight [kg]
NCR 3	51	28,5	86	68	7	G 1/8	40	7	12	0,235
NCR 10	67	36	113	90	9	G 1/4	50	9	16	0,535
NCR 22	80	42,5	128	104	9	G 1/4	60	10	16	0,940
NCR 57	100	51	160	130	13	G 3/8	80	12	20	1,800
NCR 120	120	75	194	152	17	G 3/8	100	13	24	4,250

*dimensions for mounting horizontal, bore ØE

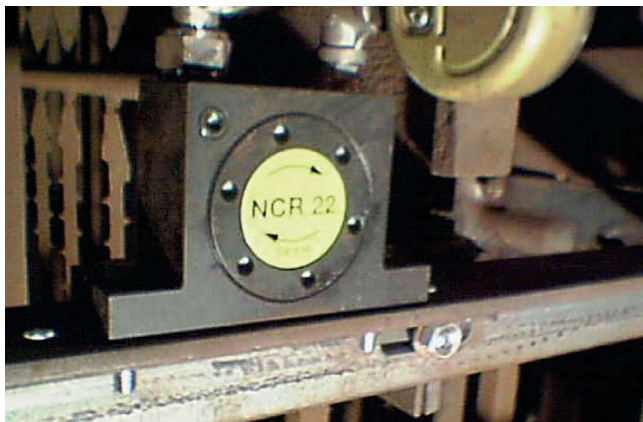
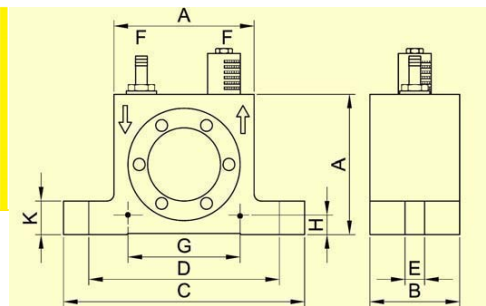

Dusting off filter wires



Emptying silo trailers

Applications

Pneumatic roller vibrators series NCR are particularly suitable for the elimination or reduction of friction.

They can be used for emptying bunkers and preventing adhesion to pipes and plates. Special features of the NCR vibrators are very high frequencies, high centrifugal forces and insusceptible resonance behaviour.

Construction and working principle

The rotary vibration is created by the high centrifugal force of a circulating steel roller, which runs on a steel ring at very high frequency.

The frequency, and hence the centrifugal force, can be continuously regulated via the operating pressure.

Series NCR roller vibrators can be operated using lubrication-free compressed air.

A multi-directional valve is required for operation (not supplied).

Permissible Operating Conditions

Drive medium:

Compressed air or nitrogen (filter ≤ 5µm) preferably with oil mist

Operating pressure:

2 bar to 6 bar

Ambient temperature:

-20°C to 120°C

HT version for temperatures up to 200°C

NetterVibration offers the accessories required for the mounting, installation, control and monitoring of vibrators and impactors.

Netter provides solutions.

Consult our experienced application technicians.

Netter GmbH

Germany

Fritz-Ullmann-Str. 9
55252 Mainz-Kastel
Tel. +49 6134 2901-0
Fax +49 6134 2901-33

Switzerland

Erlenweg 4
4310 Rheinfelden
Tel. +41 61 8316200
Fax +41 61 8311291

Poland

Al. W. Korfantego 195/17
40-153 Katowice
Tel. +48 32 2050947
Fax +48 32 2051572

www.NetterVibration.com
info@NetterVibration.com



23

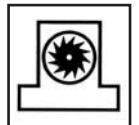

Netter Pneumatic Turbine Vibrators Series NCT

- Rotary vibration
- Resistant to aggressive environmental conditions
- Unrestricted, lubrication-free operation
- Nominal frequency from 4.900 min^{-1} to 45.460 min^{-1}
- Centrifugal force from 288 N to 8.659 N
- Frequency continuously adjustable by means of air pressure
- Reduced noise level
- Maintenance-free due to continuously lubricated rolling bearing
- Available in ATEX conform or in stainless steel versions





Netter Pneumatic Turbine Vibrators Series NCT

Type	Working moment [cmkg]	Nominal frequency [min ⁻¹]			Centrifugal force [N]			Air consumption [l/min]			Noise level [dB(A)]		
		2 bar	4 bar	6 bar	2 bar	4 bar	6 bar	2 bar	6 bar	2 bar	6 bar		
NCT 1	0,006	29.100	38.820	45.460	288	513	703	19	-	45	68	-	83
NCT 2	0,012	21.360	29.520	34.000	311	594	787	20	-	48	66	-	81
NCT 3	0,016	26.940	34.900	39.700	637	1.069	1.383	28	-	75	63	-	77
NCT 4	0,023	21.740	26.920	30.380	597	915	1.165	31	-	73	62	-	76
NCT 4i	0,046	14.020	18.560	21.000	496	869	1.112	31	-	75	61	-	73
NCT 5	0,049	22.740	27.840	30.940	1.389	2.082	2.572	93	-	284	74	-	90
NCT 10	0,096	16.940	20.680	22.980	1.511	2.251	2.780	92	-	287	66	-	78
NCT 10i	0,192	12.200	14.680	16.420	1.567	2.269	2.839	93	-	286	63	-	77
NCT 15	0,160	15.740	20.060	22.700	2.174	3.530	4.521	215	-	461	72	-	84
NCT 29	0,282	11.920	14.760	16.740	2.197	3.369	4.334	216	-	461	66	-	78
NCT 29i	0,564	7.360	10.240	11.780	1.676	3.243	4.291	213	-	463	63	-	77
NCT 55	0,545	11.000	13.980	15.760	3.618	5.845	7.426	386	-	918	77	-	85
NCT 108	1,081	8.280	10.420	11.720	4.067	6.441	8.152	379	-	911	73	-	84
NCT 108i	2,161	4.900	6.860	8.000	2.860	5.590	7.591	392	-	927	66	-	77
NCT 126	1,262	6.060	8.280	9.400	2.591	4.760	6.124	653	-	1.707	71	-	83
NCT 250	2,502	5.500	7.020	7.800	4.152	6.761	8.348	655	-	1.710	71	-	82
NCT 250i	5,000	-	5.100	5.620	-	7.131	8.659	1.222*	-	1.732	70	-	74

The technical data are relative values and can vary depending on the application. Additional data available upon request. *at 4 bar

Type	A [mm]	B [mm]	C [mm]	D [mm]	E [mm]	F	G* [mm]	H* [mm]	K [mm]	Weight [kg]
NCT 1	40	27	70	56	6,5	G 1/8	30	5,5	10	0,165
NCT 2	40	27	70	56	6,5	G 1/8	30	5,5	10	0,162
NCT 3	50	32	86	68	7	G 1/8	40	7	12	0,230
NCT 4	50	32	86	68	7	G 1/8	40	7	12	0,240
NCT 4i	50	32	86	68	7	G 1/8	40	7	12	0,250
NCT 5	65	43	113	90	9	G 1/4	50	9	16	0,550
NCT 10	65	43	113	90	9	G 1/4	50	9	16	0,570
NCT 10i	65	43	113	90	9	G 1/4	50	9	16	0,610
NCT 15	80	56	128	104	9	G 1/4	60	10	16	1,045
NCT 29	80	56	128	104	9	G 1/4	60	10	16	1,090
NCT 29i	80	56	128	104	9	G 1/4	60	10	16	1,180
NCT 55	100	73	160	130	13	G 3/8	80	12	20	2,125
NCT 108	100	73	160	130	13	G 3/8	80	12	20	2,250
NCT 108i	100	73	160	130	13	G 3/8	80	12	20	2,500
NCT 126	120	86	194	152	17	G 3/8	100	13	25	3,585
NCT 250	120	86	194	152	17	G 3/8	100	13	25	3,820
NCT 250i	120	86	194	152	17	G 3/8	100	13	25	4,290

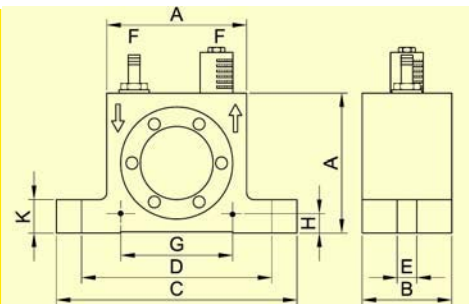

* dimensions for mounting horizontal, bore ØE

Sifting of fine grained products

Applications

Series NCT pneumatic turbine vibrators are particularly suitable for moving bulk materials. They can be used for emptying bunkers, driving chutes, sieves and vibrating tables and for the mechanical stimulation of processes.

Special features of the NCT vibrators are high frequency at low noise level and low air consumption.

Design and functioning principle

The rotary vibration is produced by an eccentrically mounted turbine with integrated unbalance masses. The frequency and therefore the centrifugal force can be continuously regulated via the operating pressure.

A directional control valve is necessary for operation (not supplied).

ATEX conform series NCT turbine vibrators and units with stainless steel housings are available.

Permissible operating conditions

Drive medium:

Compressed air or nitrogen (filter ≤ 5µm), unrestricted, lubrication-free operation

Operating pressure:

2 bar to 6 bar

Ambient temperature:

-20°C to 120°C

NetterVibration offers the accessories required for the mounting, installation, control and monitoring of vibrators and impactors.

Netter provides solutions.

Consult our experienced application technicians.

Netter GmbH

Germany

Fritz-Ullmann-Str. 9
55252 Mainz-Kastel
Tel. +49 6134 2901-0
Fax +49 6134 2901-33

Switzerland

Erlenweg 4
4310 Rheinfelden
Tel. +41 61 8316200
Fax +41 61 8311291

Poland

Al. W. Korfantego 195/17
40-153 Katowice
Tel. +48 32 2050947
Fax +48 32 2051572

www.NetterVibration.com
info@NetterVibration.com



24



Netter Pneumatic Linear Vibrators Series NTK

- Linear vibration
- Nominal frequency from 519 min⁻¹ to 3.800 min⁻¹
- Centrifugal force from 14 N to 4.748 N
- Variable additional weights
- Frequency and amplitude are separately adjustable
- Stainless steel version available
- Ex II 2 GD 85°C (T6) available (ATEX)



NTK 8 AL



NTK 25



NTK 55 AL



Netter Pneumatic Linear Vibrators Series NTK

The table shows the most frequent ratings of piston vibrators series NTK.

1 "Piston" means, that the piston vibrates, the housing is bolted to the mass to be operated.

2 The additional weights SM increase the mass of the piston and in consequence the amplitude.

3 "Housing" in the table means that the vibrator is fixed to the piston and allows additional

combinations.

4 Some vibrators may be fitted with additional weights SM at the housing.

Methods of attachment

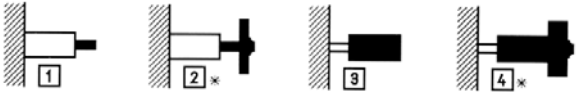

*in case of horizontal mounting with weights, please pay particular attention to the operating manual!

Type	Oscillating part		Working moment [cmkg]			Nominal frequency [min ⁻¹]			Centrifugal force [N]			Air consumption [l/min] ^{***}	Noise level [dB(A)]
	Assembly	Mass [kg] ^{**}	2 bar	4 bar	6 bar	2 bar	4 bar	6 bar	2 bar	4 bar	6 bar	2 bar – 6 bar	2 bar – 6 bar
NTK 8 AL*	Piston	0,030	0,05	0,06	0,06	2.440	3.120	3.657	15	32	44	7 – 32	61 – 75
	Piston + SM 8-1	0,046	0,08	0,10	0,10	1.858	2.412	3.000	16	32	48	6 – 31	
	Piston + 2 x SM 8-1	0,058	0,09	0,14	0,15	1.680	2.100	2.571	14	33	54	6 – 29	
	Piston + SM 8-2	0,088	0,15	0,37	0,21	1.380	1.333	2.080	15	36	50	6 – 25	
NTK15 x*	Piston	0,135	0,29	0,33	0,29	1.745	2.182	2.544	49	85	104	17 – 72	53 – 64
	Piston + SM 16-1	0,455	0,81	1,17	1,27	1.029	1.137	1.343	47	83	126	16 – 57	
	Piston + SM 16-2	0,675	1,69	1,95	1,69	758	917	1.152	53	90	123	14 – 54	
NTK16	Piston	0,150	0,27	0,37	0,34	1.680	1.920	2.400	42	75	106	14 – 58	54 – 67
	Piston + SM 16-1	0,470	1,14	1,48	1,48	908	1.309	1.527	52	139	189	11 – 44	
	Piston+SM16-1+SM 16-2	0,990	2,96	3,02	2,96	686	914	1.085	76	139	191	8 – 41	
	Housing	1,330	4,90	4,60	4,50	600	778	923	96	153	210	8 – 39	
NTK18 AL*	Piston	0,210	0,29	0,33	0,36	1.600	1.980	2.350	41	70	109	19 – 68	55 – 68
	Piston + SM 16-1	0,530	1,18	1,47	1,41	972	1.321	1.572	61	141	191	13 – 58	
	Piston + SM 16-2	0,750	1,96	2,29	2,16	878	1.168	1.371	83	171	223	11 – 56	
	Piston + SM 16-1+SM 16-2	1,050	3,27	3,27	3,21	738	965	1.174	98	167	242	10 – 50	
NTK25 AL*	Piston	0,420	1,18	1,38	1,24	1.289	1.821	1.986	107	250	269	34 – 149	56 – 73
	Piston + SM 25-1	0,775	2,59	2,95	2,88	988	1.371	1.622	139	304	415	26 – 138	
	Piston + SM 25-2	0,970	3,54	3,86	3,67	894	1.237	1.477	155	324	439	24 – 127	
	Piston + SM 25-3	1,655	6,88	6,94	6,55	686	898	1.080	177	307	419	22 – 115	
	Piston + 2 x SM 25-3	2,840	11,79	11,46	11,13	540	823	943	188	425	543	21 – 104	
NTK25	Piston	0,470	1,12	1,36	1,32	1.440	1.946	2.270	127	282	374	38 – 156	57 – 73
	Piston + SM 25-2	1,020	3,07	3,62	3,76	993	1.320	1.655	166	346	565	28 – 115	
	Piston + SM 25-3	1,705	5,58	6,41	6,34	800	988	1.292	196	343	581	25 – 105	
	Housing	2,600	9,10	9,95	9,82	690	911	1.067	237	452	612	24 – 102	
	Housing + SM 25-2	3,150	9,82	11,62	11,29	649	847	973	226	457	586	23 – 100	
	Housing + SM 25-3	3,835	11,45	14,07	13,74	609	780	933	233	469	656	23 – 100	
NTK40 AL*	Piston	1,240	2,88	2,64	2,16	1.231	1.620	2.094	239	380	519	54 – 220	58 – 70
	Piston + SM 25-3	2,475	6,72	8,40	7,44	900	1.168	1.389	298	628	787	36 – 210	
	Piston + 2 x SM 25-3	3,660	13,08	13,20	12,96	710	923	1.169	361	617	971	34 – 173	
	Piston + SM 25-4	4,910	24,24	20,64	18,72	565	780	985	424	689	995	33 – 152	
NTK40	Piston	1,270	3,57	3,57	2,46	1.200	1.629	1.930	282	520	503	49 – 228	58 – 70
	Piston + SM 25-3	2,505	7,39	8,62	8,50	889	1.175	1.433	320	653	957	38 – 188	
	Piston + 2 x SM 25-3	3,690	12,07	14,17	13,80	673	933	1.206	300	677	1.100	35 – 165	
	Housing	4,200	19,48	17,08	16,36	600	840	1.108	385	661	1.100	34 – 161	
	Piston + SM 25-4	4,940	27,10	22,67	19,71	554	778	980	456	753	1.037	32 – 152	
NTK55 AL*	Housing + SM 25-3	5,435	33,44	26,34	21,65	519	738	933	494	788	1.034	29 – 145	62 – 71
	Piston	2,100	3,62	3,50	2,66	1.500	1.920	2.400	447	708	839	98 – 398	
	Piston + SM 85-1	3,430	7,25	7,25	6,28	1.113	1.440	1.768	492	824	1.077	83 – 384	
	Piston + 2 x SM 85-1	4,610	11,11	10,87	9,90	985	1.292	1.500	591	995	1.222	81 – 371	
	Piston + SM 85-2	5,870	14,49	14,49	13,28	884	1.175	1.371	621	1.097	1.370	79 – 366	
NTK55 HF	Piston + 2 x SM 85-1+SM 85-2	8,285	22,94	22,22	20,29	758	1.011	1.200	723	1.244	1.602	73 – 355	64 – 74
	Piston	2,100	2,49	2,74	2,49	1.760	2.352	2.836	423	831	1.099	65 – 295	
	Piston + SM 85-2	3,430	4,98	6,35	6,11	1.380	1.705	2.050	520	1.013	1.407	53 – 291	

Type	Oscillating part		Working moment [cmkg]			Nominal frequency [min ⁻¹]			Centrifugal force [N]			Air consumption [l/min]**	Noise level [dB(A)]
	Assembly	Mass [kg]**	2 bar	4 bar	6 bar	2 bar	4 bar	6 bar	2 bar	4 bar	6 bar	2 bar - 6 bar	2 bar - 6 bar
NTK 55 NF	Piston	2,100	4,08	3,60	2,88	1.405	1.879	2.351	441	696	872	101 - 408	62 - 71
	Piston + 2 x SM 85-1	4,610	11,03	11,75	10,55	973	1.358	1.611	573	1.189	1.501	69 - 345	
	Housing	5,900	14,40	15,09	13,47	884	1.206	1.467	617	1.204	1.588	64 - 330	
	Piston + SM 85-1+SM85-2	7,050	18,94	19,66	18,22	853	1.140	1.380	755	1.401	1.903	63 - 321	
	Piston + SM85-3	14,630	41,37	41,97	41,97	677	862	1.015	1.039	1.708	2.371	62 - 317	
	Housing + SM85-3	18,430	46,44	52,25	49,92	649	823	960	1.071	1.940	2.523	61 - 286	
NTK 85 HF	Piston	5,200	3,01	3,76	3,88	2.520	3.120	3.800	1.047	2.006	3.075	118 - 431	64 - 79
	Piston + 2 x SM 85-1	7,710	5,01	6,39	6,27	2.031	2.466	2.954	1.133	2.130	2.997	120 - 446	
NTK 85 NF	Piston	5,200	3,91	4,67	5,04	1.892	2.400	2.830	767	1.474	2.215	166 - 545	61 - 76
	Piston + SM 85-1	6,530	6,31	6,56	6,56	1.622	2.108	2.514	910	1.597	2.273	167 - 544	
	Piston + SM 85-2	8,970	9,58	10,09	10,09	1.345	1.714	2.067	950	1.626	2.364	159 - 536	
	Housing	12,100	13,59	14,07	13,11	1.200	1.543	1.838	1.073	1.836	2.428	148 - 532	
	Piston SM 85-3	17,500	25,47	26,48	24,21	894	1.166	1.407	1.116	1.975	2.627	128 - 513	
	Piston + SM 85-2+SM85-3	21,000	32,16	32,79	30,89	821	1.060	1.297	1.187	2.021	2.851	120 - 505	
	Piston + SM 85-4	28,900	45,40	51,70	45,40	707	879	1.076	1.244	2.191	2.880	111 - 494	
Piston + SM 85-5	40,750	69,36	75,66	73,14	592	784	914	1.333	2.548	3.352	103 - 452		
NTK 110	Piston	8,000	6,03	7,87	7,87	2.133	2.571	3.040	1.505	2.852	3.986	210 - 652	62 - 78
	Piston + SM 85-2	11,770	9,18	11,27	11,80	1.760	2.160	2.538	1.559	2.884	4.169	209 - 650	
	Housing	16,600	13,48	15,68	15,93	1.447	1.846	2.133	1.548	2.930	3.974	207 - 634	
	Piston + SM 85-3	20,530	17,04	19,93	20,98	1.324	1.655	1.964	1.638	2.993	4.435	206 - 631	
	Piston + SM 85-2+SM 85-3	24,090	21,24	23,60	24,65	1.200	1.527	1.821	1.677	3.018	4.480	203 - 628	
	Piston + SM 85-4	31,990	29,89	32,78	32,51	1.046	1.292	1.632	1.794	3.001	4.748	191 - 614	
	Piston + SM 85-5	44,455	38,67	44,57	41,95	900	1.143	1.371	1.718	3.192	4.326	180 - 606	

* For lubrication free operation contact our application technicians. Subject to technical modifications.
 ** All weights inclusive fixing bolt. ***Normal litre = uncompressed air. NTK 16, 25, 40, 55, 85 and 110 operation is possible up to 16 bar.
 Technical data may vary depending on application. Please request comparative values.

NTK weights

Piston, housing, total weight

Vibrator	Piston [kg]	Housing [kg]	Total weight [kg]	Possible combinations	Additional weights	Dimensions [Ømmxmm]	Bore [Ømm]	Weight [kg]
NTK 8 AL	0,03	0,06	0,09	The combination of vibrators and weights in the same group is possible.	SM 8-1	17 x 8	5,0	0,012
NTK 15 x	0,13	0,32	0,45		SM 8-2	30 x 10	5,0	0,053
NTK 16	0,15	1,34	1,49		SM 16-1	50 x 20	10,5	0,29
NTK 18 AL	0,21	0,53	0,74		SM 16-2	65 x 20	10,5	0,51
NTK 25 AL	0,43	0,50	0,92	See table page 2 and page 3.	SM 25-1	50 x 20	16,5	0,27
NTK 25	0,47	2,63	3,10		SM 25-2	65 x 20	16,5	0,47
NTK 40 AL	1,28	1,01	2,29		SM 25-3	100 x 20	16,5	1,18
NTK 40	1,29	4,20	5,49		SM 25-4	100 x 60	16,5	3,60
NTK 55 AL	2,10	1,75	3,85		SM 85-1	100 x 20	20,5	1,16
NTK 55 HF	2,10	5,60	7,70	SM 85-2	100 x 60	20,5	3,50	
NTK 55 NF	2,10	5,90	8,00	SM 85-3	200 x 50	20,5	12,30	
NTK 85 HF	5,20	11,30	16,50	SM 85-4	200 x 100	20,5	23,70	
NTK 85 NF	5,20	12,10	17,30	SM 85-5	200 x 150	20,5	35,55	
NTK 110	8,00	16,60	24,60					

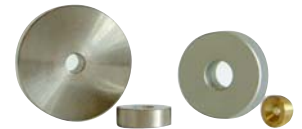

Applications

Additional weights SM are used to increase the working moment. While fixing additional weights on the moving part of the vibrator, the working moment and also the amplitude are individually adjustable.

The additional weights are available in different sizes. All weights are made of nickel-plated steel, except SM 8-1 which is made of brass.

Netter Bellows

Series NFB

Bellow	Vibrator	Inside diameter [mm]	Outside diameter [mm]
NFB 20	NTK 15 x, 16, 18 AL	20	50
NFB 25	NTK 25 AL	30	65
NFB 30	NTK 25	30	65
NFB 45	NTK 40	45	85
NFB 60	NTK 55	60	110
NFB 90	NTK 85	90	140
NFB 115	NTK 110	115	165

Applications

The bellows series NFB for linear vibrators series NTK are designed for the protection of the piston against outside influences such as dirt and dust. NFB bellows are available for all types from NTK 15x up to NTK 110. They are easily removable by velcros and make the flats of the piston accessible.





NetterVibration



Netter Pneumatic Linear Vibrators Series NTK

Type	ØA [mm]	ØB [mm]	C [mm]	E [mm]	F [mm]	G* [mm]	H	ØJ [mm]	ØK [mm]	L	M	ØQ** [mm]	R [mm]	S [mm]	T [mm]	U [mm]	SW [mm]
NTK 15 x	15	50	114	9	38	23,5	M10	-	-	G 1/8	G 1/8	-	20	10	55	99	13
NTK 16	16	49	111	5	38	21,5	M10	-	-	G 1/8	G 1/8	-	21	10	57	96	14
NTK 18 AL	18	49	116	8	42	25,0	M10	-	-	G 1/8	G 1/8	-	21	10	62	101	16
NTK 25	25	64	138	9	52	30,5	M16	-	-	G 1/4	G 1/4	-	25	10	73	125	22
NTK 40	40	84	140	12	54	33,0	M16	-	-	G 3/8	G 1/4	-	40	15	73	123	32
NTK 55NF	55	110	125	17	50	35,0	M20	96	-	G 3/8	G 3/8	4 x 8,5	40	30	60	108	46
NTK 55HF	55	110	115	27	50	40,5	M20	96	-	G 3/8	G 3/8	4 x 8,5	40	30	50	98	46
NTK 85NF	85	160	122	20	50	32,5	M20	143	12,8	2 x G 3/8	G 3/8	6 x 10,5	40	20	57	105	-
NTK 85HF	85	160	112	30	55	42,5	M20	143	12,8	2 x G 3/8	G 3/8	6 x 10,5	40	20	47	95	-
NTK 110	110	200	122	22	55	38,5	M20	182	12,8	2 x G 1/2	2 x G 3/8***	8 x 12,5	40	25	57	105	-

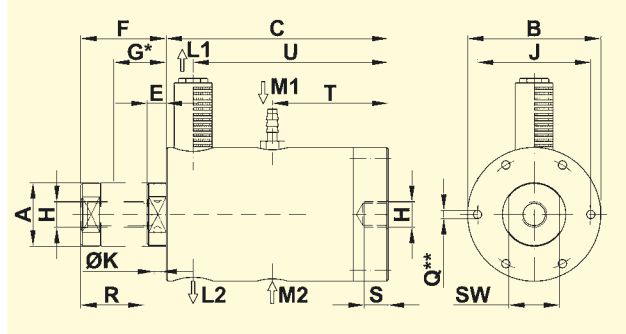

* centre of vibration
 ** additional forms of attachment from NTK 55 upwards
 *** optional M₁ or M₂

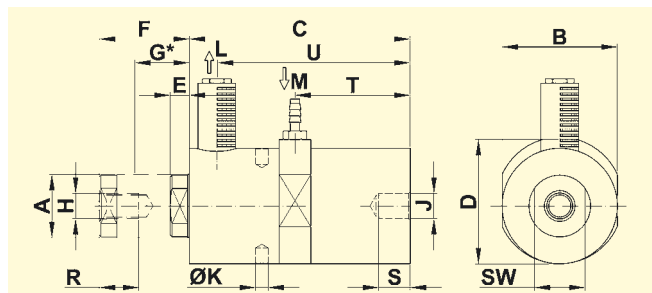

Type	ØA [mm]	B [mm]	C [mm]	D [mm]	E [mm]	F [mm]	G* [mm]	H	J	ØK [mm]	L	M	R [mm]	S [mm]	T [mm]	U [mm]	SW [mm]
NTK 8 AL	8	17	91	22	5	32	18,5	M 5	M 6	-	M 5	M 5	15	7	47	76,5	7
NTK 25 AL	25	50	138	54	7	52	29,5	M 16	M 16	-	G 1/4	G 1/4	25	18	72	120,5	22
NTK 40 AL	40	73	140	79	12	57	34,5	M 16	M 16	8	G 3/8	G 1/4	25	20	73	122,5	32
NTK 55 AL	55	98	133	109	20	58	38,5	M 20	M 20	10	G 3/8	G 3/8	40	35	66	115,0	46

* centre of vibration

Applications

The pneumatic linear vibrators series NTK are especially suitable for conveying, compacting and loosening bulk material, due to the completely linear vibration. They may also serve to stimulate and influence production processes.

A special feature of the NTK vibrators is the variety of mounting options. It is possible to attach the housing or the piston to a vibrating mass. Additional weights SM allow to adjust the frequency and the amplitude in many different ways.

Design and functioning principle

The vibration (linear) is produced by a freely oscillating, self reversing piston. NTK linear vibrators start and stop instantly in any installed position. The noise level is lower than 80 dB(A). The frequency can be adjusted continuously by regulating the air supply. The amplitude can be adjusted by throttling the exhaust air.

Vibrators with aluminium housing series NTK AL as well as type NTK 15x may be operated

lubrication-free in compliance with instructions of **NetterVibration**. NTK vibrators with steel housing require lubricated air. For operation a control valve is required (not included in scope of delivery). ATEX compliant linear vibrators of the NTK series and units with stainless steel housing are available.

Permissible operating conditions

Drive medium:

Compressed air or nitrogen (Filter ≤ 5 µm), preferably with oil mist

Operating pressure:

2 bar to 6 bar

Ambient temperature:

NTK AL 5°C to 60°C

NTK 15 x 5°C to 100°C

NTK with steel housing -10°C to 150°C

HT version up to 200°C

NetterVibration offers the accessories required for the mounting, installation, control and monitoring of vibrators and impactors.

Netter provides solutions.

Consult our experienced application technicians.

Netter GmbH

Germany

Fritz-Ullmann-Str. 9
 55252 Mainz-Kastel
 Tel. +49 6134 2901-0
 Fax +49 6134 2901-33

Switzerland

Erlenweg 4
 4310 Rheinfelden
 Tel. +41 61 8316200
 Fax +41 61 8311291

Poland

Al. W. Korfantego 195/17
 40-153 Katowice
 Tel. +48 32 2050947
 Fax +48 32 2051572

www.**NetterVibration**.com
 info@**NetterVibration**.com



25

Netter Pneumatic Linear Vibrators Series NTS



- Linear vibration
- Resistant against aggressive environmental conditions
- Nominal frequency from 827 min⁻¹ to 9.040 min⁻¹
- Centrifugal force 32 N to 21.808 N
- Frequency and amplitude can be adjusted separately
- Synchronous operation possible (NTS 350 and higher)
- Available in ATEX version or in stainless steel



NTS 120 NF



NTS 54/02



NTS 50/10



NetterVibration



Netter Pneumatic Linear Vibrators Series NTS

Type	Housing material	Working moment [cmkg]			Nominal frequency [min ⁻¹]			Centrifugal force [N]			Air consumption [l/min]		Noise level [dB(A)]	
		2 bar	4 bar	6 bar	2 bar	4 bar	6 bar	2 bar	4 bar	6 bar				
NTS 120 HF	AL	0,018	0,018	0,018	6.280	7.920	8.960	40	63	81	10	36	68	73
NTS 120 NF	AL	0,038	0,046	0,046	3.871	4.510	5.095	32	52	66	7	19	66	72
NTS 180 HF	AL	0,035	0,045	0,046	5.520	6.880	9.040	59	116	207	15	67	68	73
NTS 180 NF	AL	0,138	0,149	0,163	3.000	4.160	4.880	68	141	212	14	57	66	72
NTS 250 HF	AL	0,152	0,190	0,190	3.654	4.756	5.773	111	235	346	21	105	68	74
NTS 250 NF	AL	0,402	0,475	0,542	2.328	3.100	3.894	119	251	451	20	99	68	72
NTS 350 HF	AL	0,208	0,308	0,349	3.866	4.754	5.579	179	399	594	37	135	66	74
NTS 350 NF	AL	0,756	0,932	0,992	2.412	3.077	3.663	241	486	733	26	110	65	70

NTS 100/01*	AL	0,33	0,43	0,41	3.920	4.640	5.840	281	513	764	33	181	68	80
NTS 75/01*	AL	1,01	1,31	1,44	2.848	3.596	4.038	451	934	1.291	99	442	67	81
NTS 50/01*	AL	2,18	2,62	2,66	1.924	2.408	2.825	442	834	1.164	88	416	76	84
NTS 70/02*	AL	2,81	2,77	3,04	2.096	2.808	3.336	676	1.186	1.847	128	564	76	87
NTS 54/02*	AL	4,54	5,51	5,07	1.730	2.064	2.544	745	1.288	1.800	152	698	80	89
NTS 50/04*	AL	7,9	9,8	9,7	1.920	2.296	2.672	1.591	2.844	3.789	271	977	77	86
NTS 21/04	AL	34,9	45,9	49,1	941	1.156	1.334	1.694	3.362	4.786	225	718	73	83
NTS 50/08*	AL	11,3	15,3	17,0	1.977	2.331	2.669	2.426	4.555	6.642	216	803	81	90

NTS 50/10	GG	14,5	17,9	18,9	1.983	2.392	2.809	3.128	5.626	8.174	454	1.647	82	92
NTS 30/10	GG	50,0	80,0	96,0	840	1.044	1.300	1.940	4.780	8.900	312	1.438	75	85
NTS 50/15	GG	25,0	32,7	35,8	1.830	2.209	2.464	4.589	8.754	11.922	726	2.108	81	91
NTS 50/20	GG	24,7	34,2	37,3	1.823	2.252	2.591	4.511	9.527	13.737	887	2.491	81	92
NTS 30/20	GG	57,3	84,8	92,6	1.227	1.528	1.759	4.727	10.852	15.693	551	2.014	78	88
NTS 24/20	GG	94,2	126,6	144,8	936	1.176	1.388	4.515	9.596	15.290	642	2.083	75	80
NTS 50/40	GG	72,5	93,0	99,5	1.335	1.617	1.920	7.090	13.333	20.114	994	3.296	80	92
NTS 20/40	GG	218,9	286,7	302,3	827	985	1.147	8.227	15.239	21.808	1.340	4.252	77	89

The technical data can vary depending on application. Please request comparative values.

* oil free operation possible

Standard vibrators
NTS 120 bis NTS 350



Standard vibrators
NTS 100/01 bis NTS 20/40



Stainless steel vibrators
NTS S



ATEX compliant vibrators
NTS E

Netter Pneumatic Linear Vibrators Series NTS



Type	A	A ₁	B	C	D	ØE	F	G	H	I	K Outlet	L Inlet	Outlet on side	Housing [kg]	Piston [kg]	Total [kg]	Housing type
	[mm]	[mm]	[mm]	[mm]	[mm]	[mm]	[mm]	[mm]	[mm]	[mm]							
NTS 120 HF	97,5	70,0	27,5	SW 21	-	M 8	11	16,5	34,5	-	G1/8	G1/8	-	0,086	0,022	0,108	I
NTS 120 NF	125,0	97,5	27,5	SW 21	-	M 8	11	16,5	48,5	-	G1/8	G1/8	-	0,119	0,042	0,161	I
NTS 180 HF	108,5	73,0	33,5	SW 27	-	M10	10	19,5	35,5	-	G1/4	G1/8	-	0,124	0,050	0,174	I
NTS 180 NF	146,5	110,5	33,5	SW 27	-	M10	10	19,5	53,8	-	G1/4	G1/8	-	0,192	0,110	0,302	I
NTS 250 HF	145,5	98,0	41,5	SW 36	-	M12	12	24,0	49,0	-	G3/8	G1/8	-	0,238	0,155	0,393	I
NTS 250 NF	190,0	141,0	41,5	SW 36	-	M12	12	24,0	70,5	-	G3/8	G1/8	-	0,335	0,290	0,625	I
NTS 350 HF	146,5	99,0	53,0	SW 46	-	M12	12	30,5	49,5	-	G3/8	G1/4	-	0,359	0,325	0,684	I
NTS 350 NF	193,0	145,0	53,0	SW 46	-	M12	12	30,5	72,5	-	G3/8	G1/4	-	0,505	0,570	1,075	I

NTS 100/01	89	-	Ø69	69	-	M12	20	65,5	48,5	31,5	G1/4	G1/4	3	0,64	0,36	1,0	II
NTS 75/01	115	-	90	80	72	9	20	81	60	38	G1/4	G1/4	2	1,1	0,8	1,9	II
NTS 50/01	155	-	90	80	72	9	20	121	80	40	G1/4	G1/4	2	1,5	1,4	2,9	II
NTS 70/02	130	-	110	100	90	9	20	91	65	39	G3/8	G3/8	2	1,9	1,2	3,1	II
NTS 54/02	157	-	110	100	90	9	20	112	79	45	G3/8	G3/8	2	2,3	1,6	3,9	II
NTS 50/04	157	-	150	139	124	13	20	113	79	44	G3/8	G3/8	2	4,0	4,3	8,3	II
NTS 21/04	330	-	150	139	124	13	20	280	165	49	G3/8	G3/8	2 + 4	8,5	12,5	21	III
NTS 50/08	173	-	200	170	165	17	30	125	92	58	G3/8	G3/8	2 + 4	9,0	7,1	16,1	III

NTS 50/10	157	-	200	190	165	18	20	112	79	45	G3/8	G1/2	2 + 4	20	9,0	29	III
NTS 30/10	340	-	200	190	165	18	20	289	170	52	G3/8	G1/2	2 + 4	41	25	66	III
NTS 50/15	185	-	230	220	190	22	30	134	95	56	G3/8	G3/4	1 - 4	32	15	47	III
NTS 50/20	190	-	250	250	210	22	30	134	95	57	G3/8	G3/4	1 - 4	42	19	61	III
NTS 30/20	278	-	250	250	210	22	30	218	139	61	G3/8	G3/4	1 - 4	54	37	91	III
NTS 24/20	360	-	250	250	210	22	30	298	180	62	G3/8	G3/4	1 - 4	68	54	122	III
NTS 50/40	266	-	320	320	260	26	40	194	133	72	G1/2	G 1	1 - 4	89	52	141	III
NTS 20/40	470	-	320	320	260	25	40	392	235	78	G1/2	G 1	1 - 4	134	125	259	III

Housing type I
NTS 120 to 350

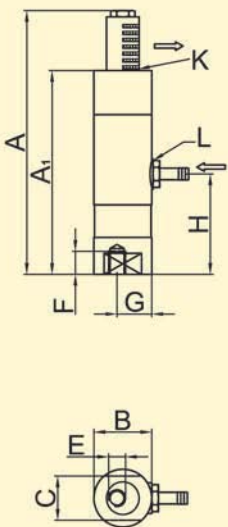

Housing type II
NTS 100/01 to NTS 50/04

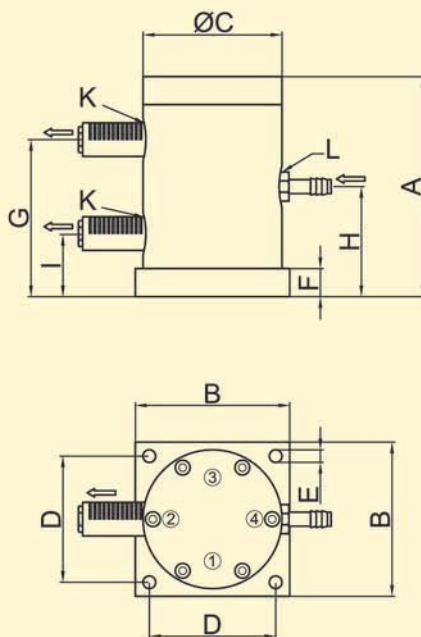

Housing type III
NTS 21/04 to NTS 20/40

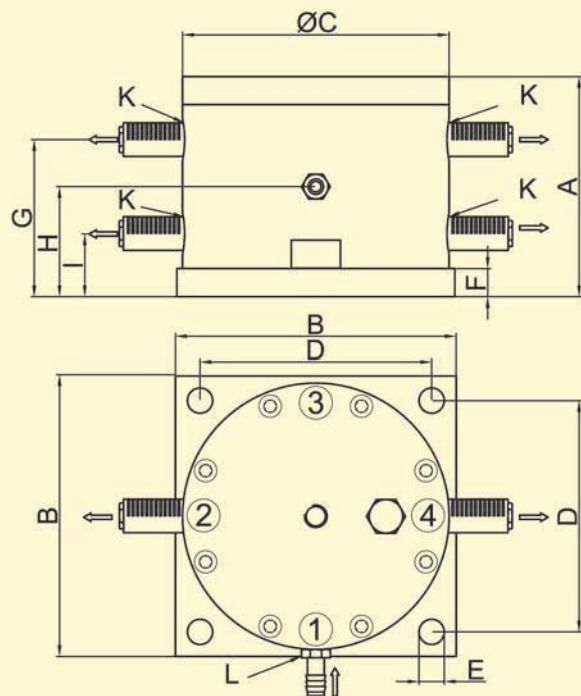



NetterVibration



Netter Pneumatic Linear Vibrators Series NTS



Filling of powder products



Maintaining material flow



Vibrating and compacting of various material in cartons



Discharging aid on the container



Conveying with Netter **PowerPack**



Compaction of form sand in foundry forms



Compaction of powder in sacks

Applications

The pneumatic linear vibrators series NTS are especially suitable for conveying, compacting and loosening bulk material, due to the completely linear vibration.

They are used to empty bins and as drives for conveyor and dosing troughs. A special feature of NTS vibrators is the possibility of the synchronous operation of several NTS when using a coupling kit. Starting from NTS 350 NF to NTS 50/08 this is available as special execution and starting from NTS 50/10 to NTS 20/40 it is standard.

Design and functioning principle

The vibration (sinus-shaped oscillation) is produced by a freely vibrating, self reversing piston. This oscillation supports, expedites or enables a variety of applications. NTS linear vibrators start and stop without delay in any installed position.

A built-in pressure spring provides a reliable start-up of vibrators with aluminium housing up to NTS 50/04 and NTS 50/08. The amplitude is set by means of the optional throttle valve.

An increase of the supply pressure causes a higher frequency. For operation a control valve is required (not included in scope of delivery). ATEX compliant linear vibrators of the NTS series and units with a stainless steel housing are available.

Permissible operating conditions

Drive medium:

Compressed air or nitrogen (Filter $\leq 5 \mu\text{m}$), preferably with oil mist

Operating pressure:

2 bar to 6 bar

Ambient temperature:

-10°C to 60°C

Aluminium housing 5°C to 60°C

NetterVibration offers the accessories required for the mounting, installation, control and monitoring of vibrators and impactors.

Netter provides solutions.

Consults our experienced application technicians.

Netter GmbH

Germany

Fritz-Ullmann-Str. 9
55252 Mainz-Kastel
Tel. +49 6134 2901-0
Fax +49 6134 2901-33

Switzerland

Erlenweg 4
4310 Rheinfelden
Tel. +41 61 8316200
Fax +41 61 8311291

Poland

Al. W. Korfatego 195/17
40-153 Katowice
Tel. +48 32 2050947
Fax +48 32 2051572

www.*NetterVibration*.com
info@*NetterVibration*.com



26

Netter Pneumatic Piston Vibrators Series NTP

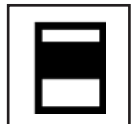

- Linear vibration
- Nominal frequency from 1.328 min⁻¹ to 8.784 min⁻¹
- Centrifugal force from 190 N to 2.039 N
- Frequency and amplitude are adjustable separately
- Available in ATEX compliant or in stainless steel



NTP 25



NTP 32



NTP 48



Netter Pneumatic Piston Vibrators Series NTP

Type	Working moment [cmkg]			Nominal frequency [min ⁻¹]			Centrifugal force [N]			Air consumption [l/min]	Noise level [dB(A)]
	2 bar	4 bar	6 bar	2 bar	4 bar	6 bar	2 bar	4 bar	6 bar	2 bar – 6 bar	2 bar – 6 bar
NTP 25 B+C	0,144	0,163	0,196	5.848	7.000	8.784	269	438	830	33 – 108	68 – 82
NTP 25 B	0,488	0,613	0,686	2.645	3.159	3.602	190	341	487	23 – 92	64 – 73
NTP 32 B+C	0,602	0,665	0,665	2.959	4.080	5.040	289	607	926	50 – 198	71 – 86
NTP 32 B	1,080	1,365	1,449	1.824	2.221	2.614	197	369	543	37 – 143	64 – 77
NTP 48 B+C	2,081	1,992	1,992	2.618	3.456	4.320	782	1.305	2.039	96 – 336	78 – 90
NTP 48 B	4,718	6,188	6,641	1.328	1.603	1.963	456	872	1.403	67 – 295	65 – 80

Standard version B+C: Bottom plate with elastomer inlay, B: Bottom plate with air cushion.
The technical data are comparative values and can vary depending on application.
Further data on demand. Subject to technical modification.

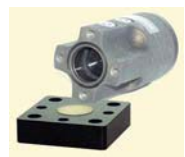

NTP B+C

Type	A [mm]	B [mm]	C [mm]	ØD [mm]	E [mm]	F [mm]	G [mm]	H [mm]	K [mm]	ØL [mm]	N [mm]	Weight [kg]
NTP 25	90	60	46	6,5	36	14,5	G 1/8	15	8	51	G 1/8	0,61
NTP 32	140	75	51	11	48	32	G 1/4	20	10	70	G 1/4	1,47
NTP 48	194	100	78	13	60	51	G 3/8	25	15	95	G 3/8	3,95



aligning of layers

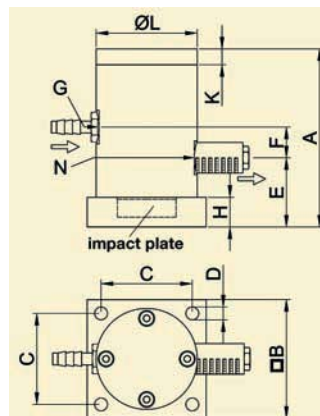

NTP 25 B+C

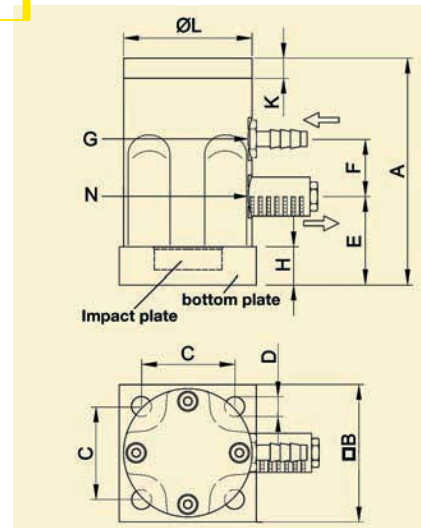

NTP 32 B+C and NTP 48 B+C

Applications

The pneumatic piston vibrators series NTP are especially suitable for knocking off material adhering to container walls in funnels, containers, silos and hoppers. They can be used as drives for vibrating tables and chutes and as assistance for emptying containers. Special features of NTP vibrators are: impacts like a rubber hammer or vibration with high peak acceleration.

Design and functioning principle

The vibration (linear) is produced by a freely vibrating differential pressure piston. In the standard version B+C the piston is knocking against an elastomer impact plate and works like a rubber hammer. In the version B without impact plate the piston works against an air cushion (noise reduced). Hard knocking versions available. The frequency can be adjusted by varying the pressure of the air supply and the amplitude by throttling the exhaust.

For operation a control valve is required (not included in scope of delivery). Lubrication-free operation is possible in compliance with the recommendations of Netter.

ATEX compliant linear vibrators of the NTP series and units with stainless steel housing are available.

Permissible operating conditions

Drive medium:

Compressed air or nitrogen (Filter ≤ 5 µm), preferably with oil mist

Operating pressure:

2 bar to 6 bar

Ambient temperature:

5°C to 60°C

NetterVibration offers the accessories required for the mounting, installation, control and monitoring of vibrators and impactors.

Netter provides solutions.

Consult our experienced application technicians.

Netter GmbH

Germany

Fritz-Ullmann-Str. 9
55252 Mainz-Kastel
Tel. +49 6134 2901-0
Fax +49 6134 2901-33

Switzerland

Erlenweg 4
4310 Rheinfelden
Tel. +41 61 8316200
Fax +41 61 8311291

Poland

Al. W. Korfanteo 195/17
40-153 Katowice
Tel. +48 32 2050947
Fax +48 32 2051572

www.NetterVibration.com
info@NetterVibration.com



27

Netter Pneumatic Impactors Series PKL



- Higher impact power than traditional impactors
- Lower compressed air requirement per impact
- Low-noise versions with elastomer insert EE
- Versions with automatic control ST
- ATEX or stainless steel versions available



PKL 450



PKL 740



PKL 2100



NetterVibration



Netter Pneumatic Impactors Series PKL

Type	Piston Weight [kg]	Impact Force* [kg]	Optimum Operating Pressure [bar]	Air Requirement/Impact at Optimum Pressure [Normalliter]	Total Weight [kg]	Suitable for Wall Thickness [mm]
PKL 190/4	0,19	0,43	4,0	0,09	0,8	1 – 2
PKL 190/6	0,19	0,60	6,0	0,14	0,8	1 – 2
PKL 450/4	0,44	0,56	4,0	0,13	1,6	1 – 3
PKL 450/6	0,44	0,92	6,0	0,18	1,6	1 – 3
PKL 740/3	0,74	1,30	3,0	0,27	2,6	2 – 4
PKL 740/4	0,74	1,80	4,0	0,38	2,6	2 – 4
PKL 740/5	0,74	2,10	5,0	0,43	2,6	2 – 4
PKL 740/6	0,74	2,70	6,0	0,54	2,6	2 – 4
PKL 2100/4	2,10	4,20	4,0	1,55	7,8	3 – 5
PKL 2100/5	2,10	6,30	5,0	1,93	8,0	3 – 5
PKL 5000/4	4,96	6,60	4,0	1,50	16,0	4 – 8
PKL 5000/4 S	4,96	6,60	4,0	1,50	16,0	4 – 8
PKL 5000/6	4,96	10,80	6,0	2,20	16,5	6 – 12
PKL 5000/6 S	4,96	10,80	6,0	2,20	16,5	6 – 12

PKL 240/4	10,50	12,40	4,0	2,00	24,0	10 – 12
PKL 240/6	10,50	16,60	6,0	3,01	24,1	> 10

*The impact corresponds to the effect of the given weight, when dropped from a height of 1 m.

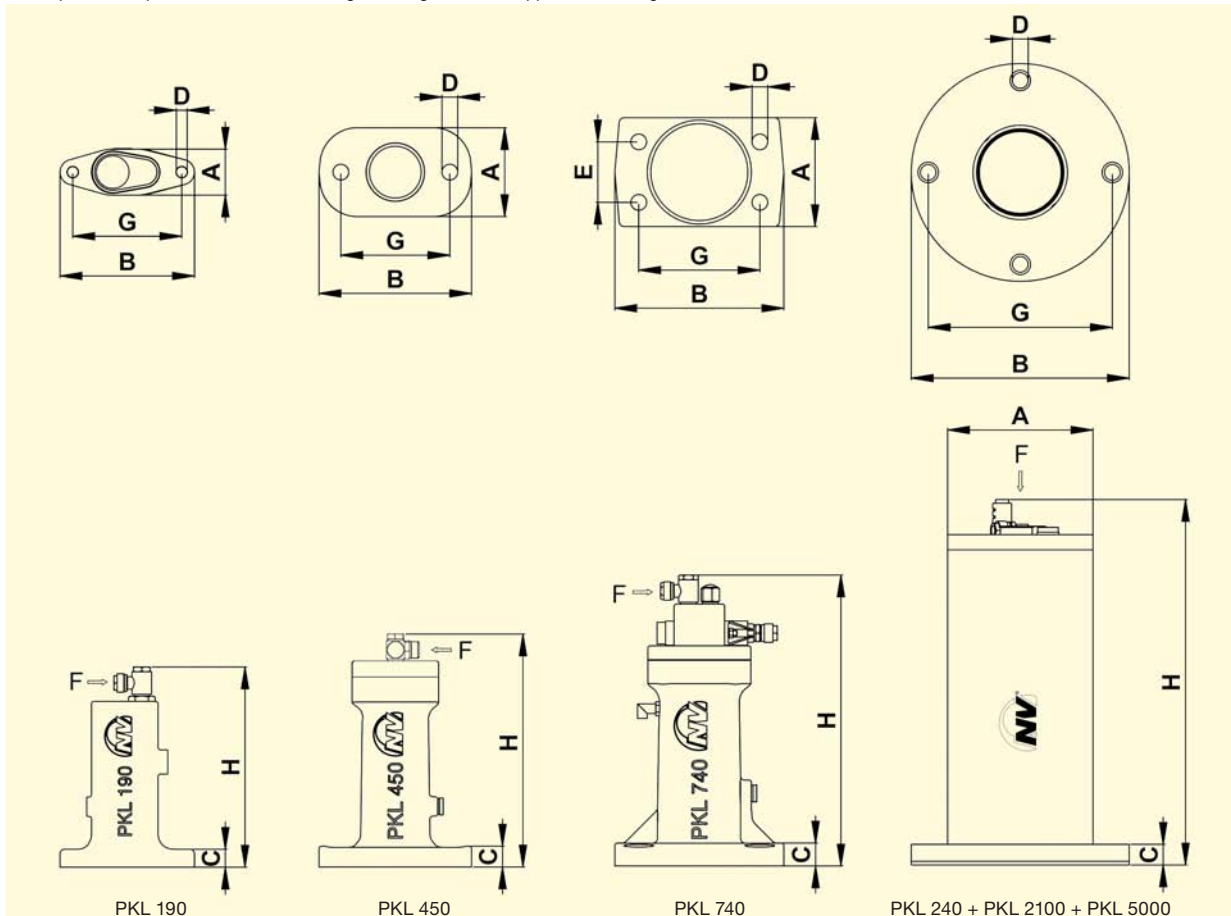

	A [mm]	B [mm]	C [mm]	Ø D [mm]	E [mm]	F	G [mm]	H [mm]
PKL 190	38	111	15	9,0	—	G 1/8, NW 6×1	90	163,5
PKL 450	73,5	126	14	13,0	—	G 1/8, NW 6×1	90	192,0
PKL 740	90	140	15	13,0	50	G 1/8, NW 6×1	100	238,5
PKL 2100	Ø 120,0	Ø 180	17	13,0	—	G 1/8, NW 6×1	Ø 152	301,5
PKL 5000	Ø 114,3	Ø 180	22	17,0	—	G 1/8, NW 6×1	Ø 152	376,5

PKL 240	Ø 114,3	Ø 180	27	17,0	—	G 1/8, NW 6×1	Ø 152	405,0
---------	---------	-------	----	------	---	---------------	-------	-------

Netter Pneumatic Impactors Series PKL



ST Kit

Applications

The ST kit enables a continuous impact sequence when connected to a permanent compressed air supply.

Impact Frequency

The impact frequency can be adjusted by means of a throttle valve installed in the air supply line. The maximum impact sequence must be observed.

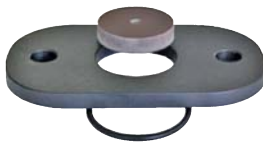

EE Kit

Applications

The EE kit is used to produce a low-noise impact or "rubber hammer effect".

Design and Function

A spacer plate with an elastomer insert, is installed between the impactor and the mounting surface of types PKL 190, 450 and 740. The existing strike plate of PKL 240, 2100 and 5000 is replaced by an elastomer plate which reduces considerably the noise level.



Special Versions ATEX / Stainless Steel / High Temperature

PKL E (ATEX)

Netter series PKL E pneumatic impactors comply with directive 94/9/EC (ATEX product directive) device group II and are suitable for use in potentially explosive areas of category 2 (2G and 2D 85°C[T6]) in zones 1, 2, 21 and 22.

PKL S (Stainless Steel)

Stainless steel intermittent impactors satisfy the specific requirements for chemical resistance of the surfaces.

PKL HT (High Temperature)

The HT series is designed for use at ambient temperatures of up to 160°C.



Weld-On Consoles

Applications

Welding consoles ASB and welding plates ASP, available as straight or round versions, are suitable for attachment to square, round and conical containers.

They allow optimum transfer of the impulses produced by the impactor, while reducing the loads on weld seams and container walls.

Design and Function

The weld-on consoles are welded directly to the container. The impactor is then screwed to the console using fixing set NBS.



Fixing Sets NBS

Applications

NBS fixing sets provide a safe and permanent fixing of PKL impactors.

NBS fixing sets consist of special screws,

damping elements, washers and nuts, to suit the respective application.

The fixing sets are available in different executions.



Control Valves

Applications

Directional control valves are necessary for the control of impactors.

They can be activated either by hand or by means of an electronic timer.

Our product range includes electric, pneumatic and manually operated valves.



Electronic Timer AP and PAP

Applications

Electronic timers are used for the control of impactors, solenoid valves and contactors, wherever a process requires variable timing.

Design and Function

The adjustable duty time or pause time of the AP 116 has a control function by means of an electric signal (e.g. to a solenoid valve). The pneumatic duty-pause controls (PAP 115 and PAP 116) directly control the compressed air supplied to the system and can be used in wet areas.

Controlling the duty time reduces energy consumption and noise levels.



NetterVibration



Netter Pneumatic Impactors Series PKL



Insulation hoods

Applications

The use of hoods is particularly worthwhile for bunkers with insulation covers.

Attaching the insulation hood to the insulation cover fully insulates the source of the noise (bunker).



Vacuum Fixing Devices VAC

Applications

Series VAC vacuum fixing devices serve the fast fixation of impactors on smooth or, under certain circumstances, rough or curved surfaces. They allow quick and simple attachment without welding or screwing.

Design and Function

As soon as compressed air is supplied to the VAC mounting, the device is sucked tight, ensuring a force-locked connection between the impactor and the mounting surface. ATEX compliant mountings and units with stainless steel plates are available.



Cleaning pipes



Cleaning bunker walls



Cleaning weighing containers

Applications

Series PKL pneumatic impactors are particularly suitable for knocking stubborn residues from walls, pipes and containers.

Examples of applications include: elimination of tubefforming, bridging and evacuation of residues.

Design and Function

The impact (similar to a hammer) is created by the piston. With PKL 190 to 740 the impact is produced directly against the surface upon which the impactor is mounted. From PKL 240 to PKL 2100 and PKL 5000 the piston hits the base plate. The compressed air pushes the piston against one or two springs.

The fast exhausting of the piston chamber causes the piston to strike abruptly against the impact surface. Series PKL impactors can be operated using nonlubricated compressed air. A directional control valve is necessary for activation (not included).

The maximum impact sequence is 10 impacts in a row, at a rate of 15 impacts per minute and 180 impacts per hour.

Permissible Operating Conditions:

Drive Medium:

Compressed air or nitrogen (filter $\leq 5 \mu\text{m}$), Preferably with oil mist

Operating Pressure:

2,5 bar to 6 bar

Ambient Temperature:

-20°C to 60°C

HT version up to 160°C

NetterVibration offers the accessories required for the mounting, installation, control and monitoring of vibrators and impactors.

Netter provides solutions.

Consult our experienced application technicians.

Netter GmbH

Germany

Fritz-Ullmann-Str. 9
55252 Mainz-Kastel
Tel. +49 6134 2901-0
Fax +49 6134 2901-33

Switzerland

Erlenweg 4
4310 Rheinfelden
Tel. +41 61 8316200
Fax +41 61 8311291

Poland

Al. W. Korfatego 195/17
40-153 Katowice
Tel. +48 32 2050947
Fax +48 32 2051572

www.*NetterVibration*.com
info@*NetterVibration*.com

08/2012 Subject to change without notice

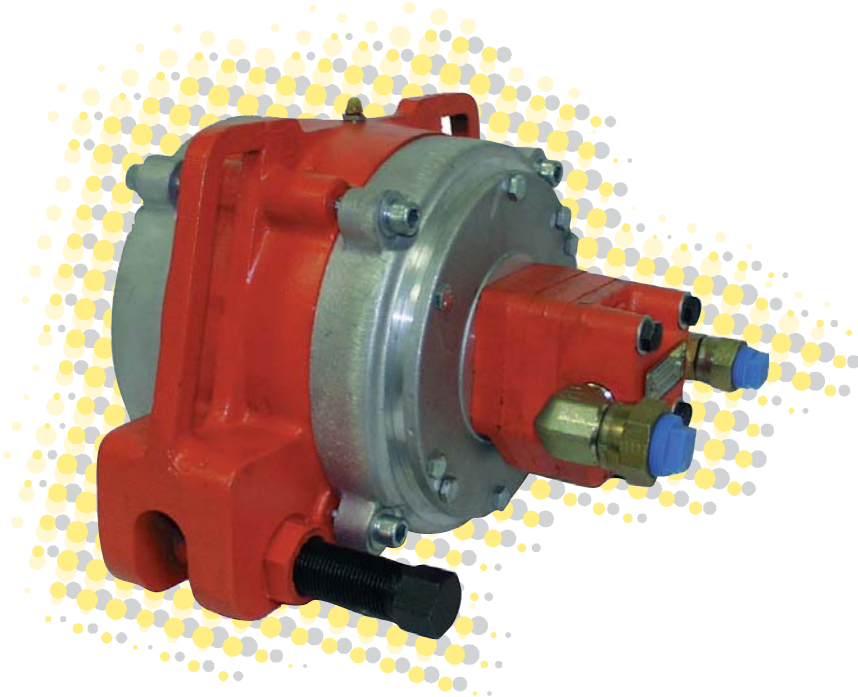

30

Netter Hydraulic External Vibrators Series CC, CV, CCV and DV



- Driven by flanged hydraulic motor
- Nominal frequency from 1.750 min⁻¹ to 5.400 min⁻¹
- Centrifugal force from 7.320 N to 49.210 N
- Frequency continuously adjustable by hydraulic pressure
- High working moment, high amplitude
- Low unit weight combined with high capacity
- Mounting by attachment screw (CCV), bracket (CC) or flange (CV/DV)



CV 2.8



CC 2.8



CCV 6



DV 6



NetterVibration



Netter Hydraulic External Vibrators Series CC, CV, CCV and DV

Type	Unbalance adjustment **	Working moment [cmkg]	Starting pressure [bar]	Frequency* [U/min]	Volume flow [l/min]	Centrifugal force [N]	Frequency* [U/min]	Volume flow [l/min]	Centrifugal force [N]	Weight [kg]
CC2.8-5HB	1	18,3	13	2.700	15,5	7.320	4.400	26,5	19.430	
	2	18,0	12	2.800	15,9	7.740	4.500	25,7	19.990	17,0
CV2.8-5HB	3	16,9	10	2.800	17,0	7.270	4.600	26,9	19.610	16,5
CCV 4-5HB	4	15,3	9	3.300	18,9	9.140	4.800	27,3	19.330	20,0
DV 4-5HB	5	12,8	9	3.800	21,6	10.140	5.000	28,8	17.550	19,0
	6	9,8	7	4.000	22,7	8.600	5.400	30,3	15.670	
CCV6-12-8HA	0 - 100 %	28	8	2.750	34,0	11.610	3.500	45,8	18.810	39,0
DV6-12-8HA										44,7
CCV6-25-8HA	0 - 100 %	59	9	2.500	30,7	20.220	3.900	43,5	49.210	40,4
DV6-25-8HA										46,1
CCV6-50-8HA	0 - 100 %	119	11	1.750	23,5	19.980	2.600	34,1	44.110	44,2
DV6-50-8HA										49,9

CC = mounting with bracket NVH
CCV = mounting with attachment screw

DV/CV = mounting with flange screw
5 HB/8 HA = hydraulic motor

* Notice: Hydraulic external vibrators for higher frequency see leaflet series NHG.

**The working moment of series CC, CV, CCV and DV 2.8/4 is adjustable in 6 steps.

Type	A [mm]	B [mm]	C [mm]	D [mm]	E [mm]	F [mm]	G [mm]	H [mm]	Outlet J	Inlet K
CV 2.8	250,8	174,6	249,2	203,2	76,2	87,3	23,8	22,0	3/4"	1/2"
CC 2.8	228,6	181,0	241,3	-	76,2	87,3	-	-	3/4"	1/2"
CCV 4	292,1	209,6	244,5	209,6	23,8	104,8	-	-	3/4"	1/2"
DV 4	304,8	206,4	244,5	4 bores: 63,5 x 266,7	101,6	101,6	22,2	16,5	3/4"	1/2"
CCV 6	368,3	287,3	320,7	285,8	25,4	142,9	-	-	3/4"	1/2"
DV 6	457,2	279,4	320,7	6 bores: 50,8 x 50,8 x 406,4	152,4	141,3	28,6	22,0	3/4"	1/2"

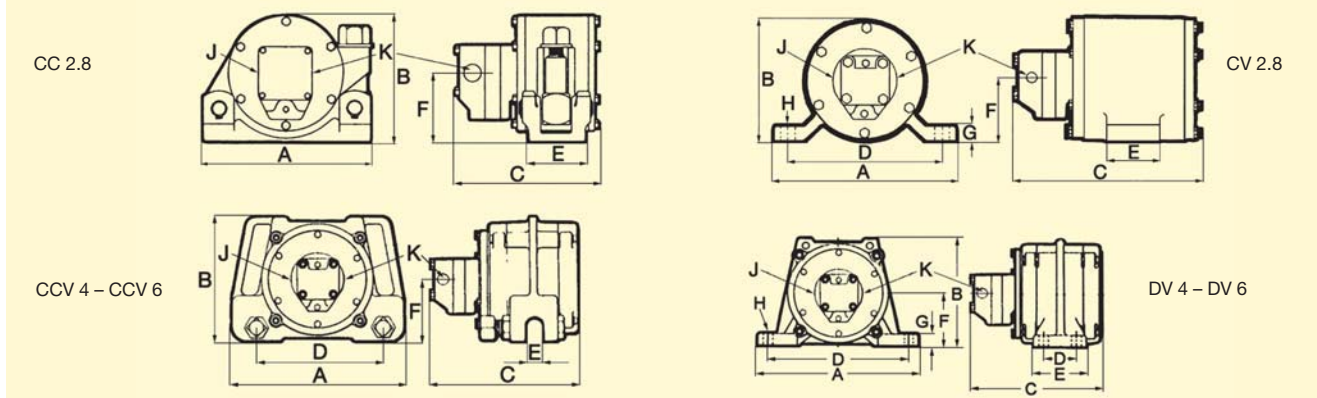

Application

Netter hydraulic external vibrators series CV, CC, CCV and DV are especially suitable to unload rail wagons and bulk hoppers as well as for the sieving and compacting of different materials.

Trucks and tractors which use hydraulic energy for dumping and lifting, are sources of hydraulic power.

A special feature of CC/CCV vibrators is the quick manual repositioning.

Design and functioning principle

The vibration (circular) is produced by unbalance pairs with double bearings.

The frequency and thus the centrifugal force are continuously adjustable by the volume flow. The hydraulic external vibrators generate high amplitudes with low frequencies.

The working moment of series CC, CV, CCV and DV 2.8/4 is adjustable in 6 steps. The working moment of series DV 6-12,

-25 and -50 is continuously adjustable. The only difference between the units is the execution of the housings. The vibrators generate very high forces in proportion to their weight.

Permissible operating conditions

Drive medium:

Hydraulic oil (clean and filtered)
DIN 51524/25 or motor oil DIN 51511

Operating pressure:

Max. 80 bar inlet,
max. 2 bar outlet.

Ambient temperature:

- 20°C to 60°C

NetterVibration offers the accessories required for the mounting, installation, control and monitoring of vibrators and impactors.

Netter provides solutions.

Consult our experienced application technicians.

Netter GmbH

Germany

Fritz-Ullmann-Str. 9
55252 Mainz-Kastel
Tel. +49 6134 2901-0
Fax +49 6134 2901-33

Switzerland

Erlenweg 4
4310 Rheinfelden
Tel. +41 61 8316200
Fax +41 61 8311291

Poland

Al. W. Korfatego 195/17
40-153 Katowice
Tel. +48 32 2050947
Fax +48 32 2051572

www.NetterVibration.com
info@NetterVibration.com



32

Netter Hydraulic External Vibrators Series NHG L

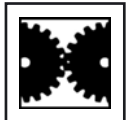

- Rotary vibration
- Nominal frequency from 3.500 min⁻¹ to 7.000 min⁻¹
- Centrifugal force from 4.070 N to 25.600 N
- Frequency continuously variable via volume flow rate



NHG 500 L



NHG 3000 L



NetterVibration

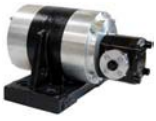

Netter Hydraulic External Vibrators Series NHG L

Type	Working moment [cmkg]	Normal Operation ED 100%			Short Operation ED ≤ 60%			Weight [kg]
		Frequency [U/min]	Centrifugal Force [N]	Oil Requirement [l/min]	Frequency [U/min]	Centrifugal Force [N]	Oil Requirement [l/min]	
NHG 500 L	2,06	6.000	4.070	12	7.000	5.550	14	6,4
NHG 600 R L	0 to 3	6.000	5.922	12	7.000	5.723*	14	8,2
NHG 900 L	6,64	4.000	5.870	8	5.000	9.100	10	7,7
NHG 3000 L	29,18	3.500	19.600	20	4.000	25.600	22	29,0

*The working moment must be reset to 2.19 cmkg.

Type	A [mm]	B [mm]	C [mm]	D [mm]	E [mm]	F [mm]	Ø G [mm]	H [mm]	I [mm]	K [mm]	Ø L	M [mm]	Ø P	Ø R
NHG 500 L NHG 600 R L NHG 900 L	194	120	120	160	24	36	17	212	80	37	G1/4	47	G1/4	G3/8
NHG 3000 L	260	195	140	200	30	80	17	310	70	50	M12x1,5	96	G3/8	G3/8

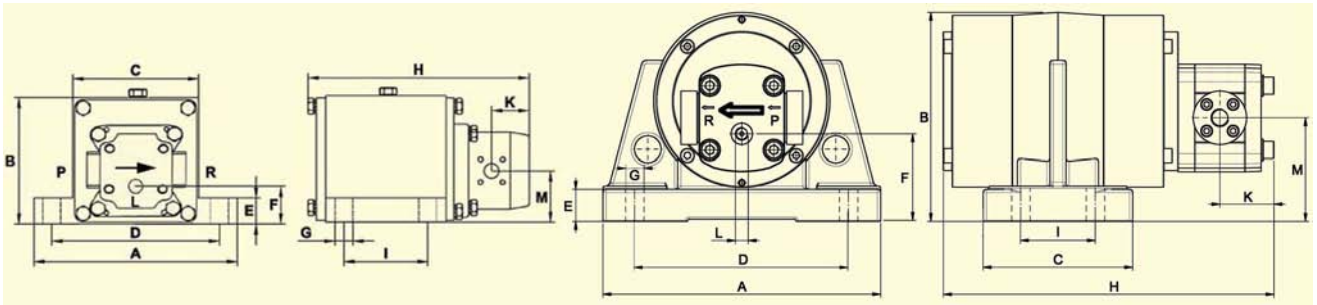

NHG 500 L, NHG 600 R L and NHG 900 L

NHG 3000 L



NHG 3000 L



Emptying silo vehicles



NHG 900 L

Applications

Series NHG L hydraulic external vibrators are particularly suitable for emptying containers and bulk material hoppers containing adherent bulk materials, for preventing bridging and tubing and for compacting various materials. A special characteristic is its use for unloading transport vehicles, e.g. trucks, silo buses and ships. The vibrators are driven via the hydraulic system belonging to the carrier vehicle, and are therefore independent of any external energy supply.

Design and functioning principle

The rotary vibration is created by an unbalance. High rotational speeds result in large centrifugal forces. The rotational speed, and hence the centrifugal force, can be regulated continuously via the volume flow rate. NHG 500 L, NHG 900 L and NHG 3000 L have fixed working moments. The working moment of the NHG 600 RL can be adjusted in steps, from the outside.

Series NHG L hydraulic external vibrators are also available without an overflow oil line connection.

The pressure in the return line must not exceed 2 bar.

Permissible operating conditions:

Drive Medium:

Clean, filtered hydraulic oil DIN 51524/25 or engine oil DIN 51511

Operating pressure:

Pressure side 200 bar max.
Overflow oil line back pressure 2 bar max.

Ambient temperature:

-20°C to 80°C
-20°C to 60°C NHG 3000

NetterVibration offers the accessories required for the mounting, installation, control and monitoring of vibrators and impactors.

Netter provides solutions.

Consult our experienced application technicians.

Netter GmbH

Germany

Fritz-Ullmann-Str. 9
55252 Mainz-Kastel
Tel. +49 6134 2901-0
Fax +49 6134 2901-33

Switzerland

Erlenweg 4
4310 Rheinfelden
Tel. +41 61 8316200
Fax +41 61 8311291

Poland

Al. W. Korfatego 195/17
40-153 Katowice
Tel. +48 32 2050947
Fax +48 32 2051572

www.NetterVibration.com
info@NetterVibration.com



35

Netter Timer Type AP 116 and Series PAP



- Adjustment exact to the second
- Dust and water-splash protected
- For the control of electric and pneumatic vibrators



AP 116



PAP 115



PAP 116



NetterVibration



Netter Timer Type AP 116 and Series PAP

Type	AP 116	PAP 115	PAP 116
Operation mode	electric, non-contact	pneumatic	pneumatic
Adjustment	digital	analogue	analogue
Duty time	hh : mm : ss, 1 s to 99 h	3 s to 180 s (down)	3 s to 180 s (down)
Pause time	hh : mm : ss, 1 s to 99 h	3 s to 180 s (up)	3 min to 100 min (up)
Switching current	AC / DC: 1,25 A	-	-
Own consumption	2 VA (in operation), 0,25 VA (standby)	-	-
Input/output	AC 90 V – 240 V (50/60 Hz) DC 24 V – 48 V ± 5 %	1/8"	1/8"
Operation pressure	-	minimum 3 bar	minimum 3 bar
Ambient temperature	-20°C to 60°C	-10°C to 60°C	-10°C to 60°C
Protection	IP 65, radio interference suppression	IP 66	IP 66
Housing	polycarbonate	Al	Al

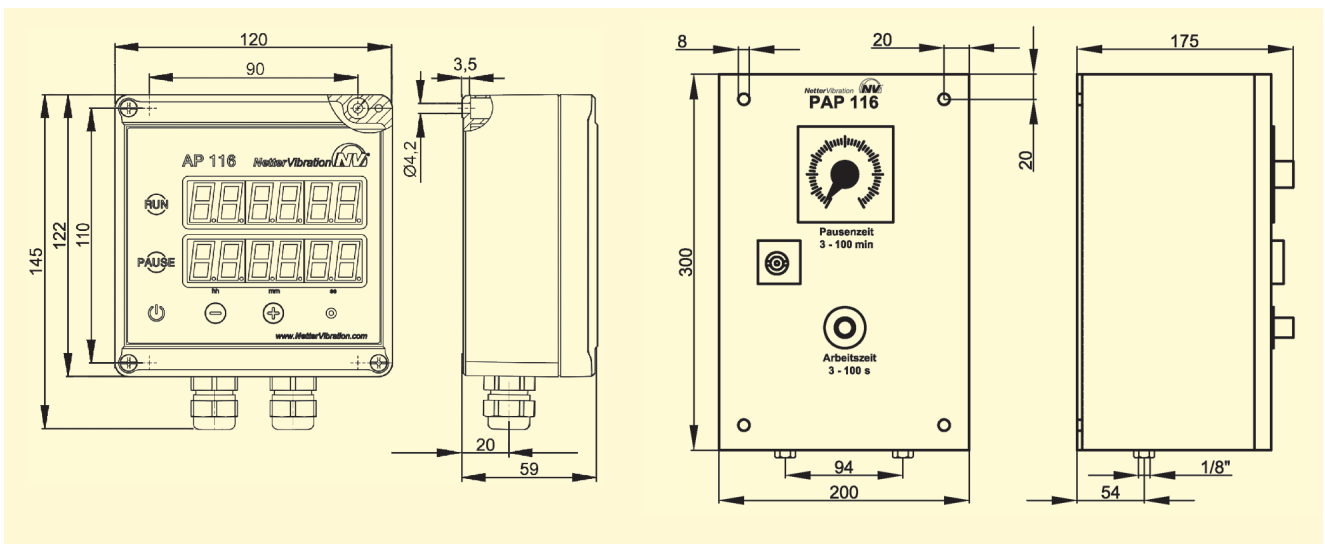

AP 116

Applications

The electronic timer AP116 is used to control pneumatic and electric vibrators. The advantages of temporary vibrator application are that noise levels can be reduced and energy saved.

Construction and Working Principle

The electronic timer is used to operate solenoid valves or motor overheating protection at freely selectable intervals. The sequence begins with the duty time, which can be adjusted from 1 s to 99 h. During this time the supply voltage is applied to the consuming device being controlled. When the duty time ends, the pause time of 1 s to 99 h is run, then the duty time, etc. The elapsed time is visible on the display. The A116 can be used separately or integrated in a switching cabinet.

PAP 115 and PAP 116

Applications

Series PAP pneumatic time controls are suitable for interval control of vibrators, as well as the control of impactors (PKL). The times can be continuously adjusted.

Construction and Working Principle

Activation (on/off) with a directional control valve. The PAP can actuate all directional, valves, but is not sufficient for the direct activation of consuming devices. It must be ensured that enough adequately sized actuation valves are provided for vibrators, etc. The pause time of the PAP 115 can be adjusted exact to the second, that of the PAP 116 exact to the minute. Use filtered (filter $\leq 5 \mu\text{m}$) compressed air. Constant pressure guarantees reproducible times.

NetterVibration offers the accessories required for the mounting, installation, control and monitoring of vibrators and impactors.

**Netter provides solutions.
Consult our experienced application technicians.**

Netter GmbH

Germany

Fritz-Ullmann-Str. 9
55252 Mainz-Kastel
Tel. +49 6134 2901-0
Fax +49 6134 2901-33

Switzerland

Erlenweg 4
4310 Rheinfelden
Tel. +41 61 8316200
Fax +41 61 8311291

Poland

Al. W. Korfantego 195/17
40-153 Katowice
Tel. +48 32 2050947
Fax +48 32 2051572

www.NetterVibration.com
info@NetterVibration.com

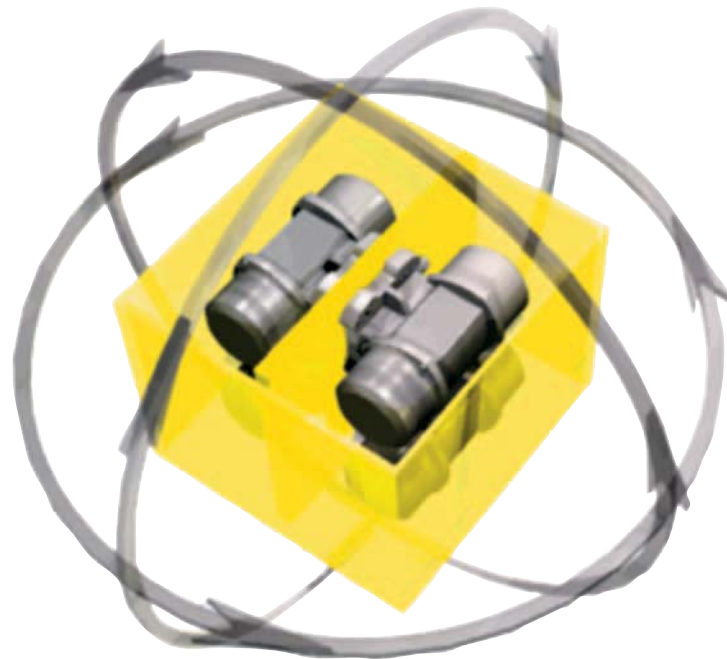

37

Netter Multiple-Shaft Vibration Systems Series *VectorDrive*



- 100% controlled vibration in each direction
- Resonance-free start and stop
- Amplitude adjustment during operation
- Frequency control during operation
- Constant acceleration with varying loads
- Prevention of resonance and associated noise
- Operating times of less than 1 second possible
- Control loops for acceleration possible

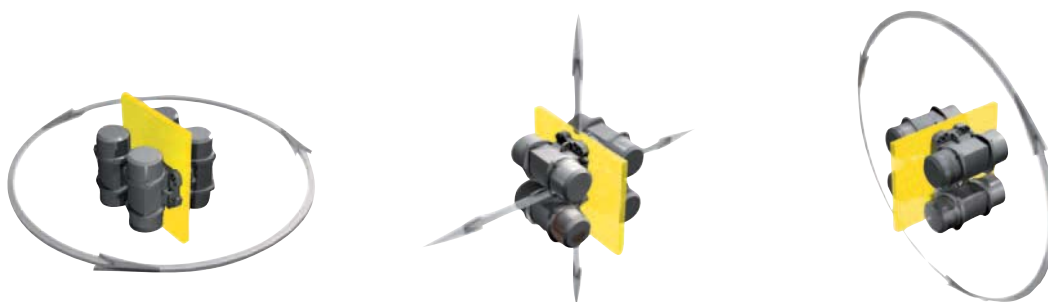



Netter Multiple-Shaft Vibration Systems Series *VectorDrive*

Horizontal arrangement of vibrators

E.g. for mixing, feeding, compacting and rocking

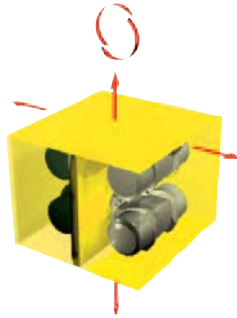

Vertical arrangement of vibrators

E.g. for mixing, tumbling, compacting and sieving

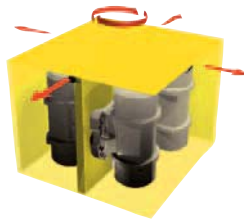

Linear arrangement of vibrators

(compact mounting)

E.g. for feeding, compacting and rocking

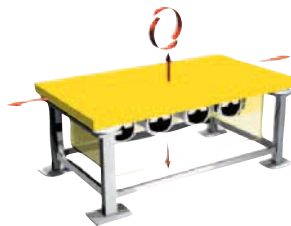

VectorDrive



Visual aging of paving stones

Applications:

The multiple-shaft vibration system **VectorDrive** offers a multitude of application possibilities.

The resonance-free starting and stopping, together with independent regulation of the working direction, frequency and amplitude open up new possibilities for compacting, mixing, feeding and distributing.

Design and Function:

The **VectorDrive** system consists of a control unit and at least 4 vibrators.

For an electric vibrator there are generally two operating conditions and two transitional phases: standstill (no vibration), nominal rotational speed (vibration) and acceleration up to nominal rotational speed or deceleration down to standstill. Often, however, only the two operating conditions, standstill and nominal rotational speed, are desired, since detrimental resonance zones must be passed through in the transitional phases.

Example: Bulk material is optimally compacted using external vibrators at 3000 revs/min. When passing through rotational speeds between 1700 revs/min and 1300 revs/min, undesirable loosening can occur. The best solution would be to simply switch on the vibration at the nominal rotational speed and then switch it off again.

The control unit of the **VectorDrive** system makes this desired "on/off" effect (vibration / no vibration) possible.

Within a fraction of a second, the unbalances are positioned with each other in a way that allows the required centrifugal force and working direction.

Independent of the arrangement of the vibrators on the table, it is possible to create circular vibrations, as well as linear vibrations, by a change of the working direction. The various working directions can be controlled successively during operation, also with changing frequencies and amplitudes.

The **PowerCube** is the preferred variant for the arrangement of the vibrators. The vibrators, in this case, are arranged in a cube under the table. The vibrators can be easily rearranged by dismounting and rotating the cube. Of course, it can just as easily be mounted under a different table construction.

Netter supplies solutions. Consult our experienced application technicians.

Netter GmbH

Germany

Fritz-Ullmann-Str. 9
55252 Mainz-Kastel
Tel. +49 6134 2901-0
Fax +49 6134 2901-33

Switzerland

Erlenweg 4
4310 Rheinfelden
Tel. +41 61 8316200
Fax +41 61 8311291

Poland

Al. W. Korfantego 195/17
40-153 Katowice
Tel. +48 32 2050947
Fax +48 32 2051572

www.**NetterVibration**.com
info@**NetterVibration**.com



38

Netter vibration monitoring system Series *VibroMonitor*

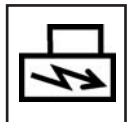

- Monitoring the operation of vibrators and impactors
- Constant checkup of vibration systems
- Control unit mounted on M36-DIN rail



NVM C1W

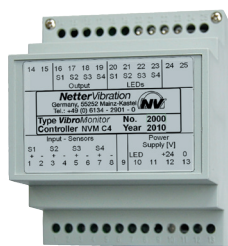

NVM C4W



NVM S10



NetterVibration



Netter vibration monitoring system Series *VibroMonitor*

<i>VibroMonitor</i>	NVM C1W Control unit	NVM C4W Control unit	NVM C4 Control unit	NVM S10 Sensor
Sensor inputs	1 x unpolarised	4 x unpolarised	4 x unpolarised	
Relay outputs	1 x potential-free change-over	4 x potential-free change-over	–	
Digital outputs	1 x sensor status, NPN, max. 1 A		4 x sensor status, NPN, max. 8 mA	
Einstellung	–	2 x SET Eingänge	–	
Status-LEDs	1 x operating voltage control		1 x operating voltage control,	Shock acceleration max. 981 m/s ²
	1 x sensor status	8 x sensor status	4 x sensor status	
Faults	1 x fault output (cable break or short circuit)		4 x visual indicators	Cable length between sensor and control unit: max. 250 m
Mounting	70 x 35 x 90 mm	70 x 70 x 90 mm	70 x 70 x 90 mm	Ø 12 x 40, thread (plug) M12 x 1
Dimensions H x L x W	M36-DIN-standard rail (EN50022)			

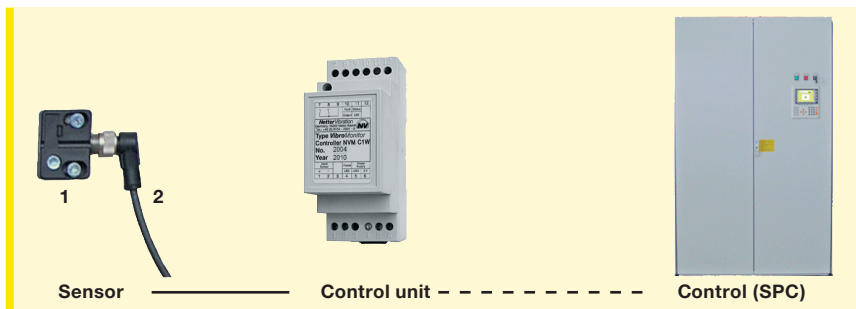

Accessories

- 1 Sensor clamp support in plastic or rubberised stainless steel pipe clamp.
- 2 Elbow connector M12 x 1 or sensor connector cable with cast elbow connector M12 x 1

Vibrator monitoring

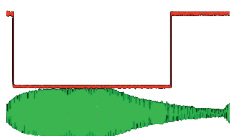

The *VibroMonitor* output (red) shows the acceleration (green) exceeding the switching threshold* of 9,81 m/s².
*Can be adjusted in the factory.

Impactor monitoring

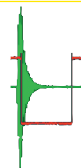

The *VibroMonitor* output (red) holds its status for at least 450 ms. and therefore reliably records even short impacts (green). This signal length is treatable by standard commercial SPCs.

Applications

The vibration monitoring system series *VibroMonitor* is used for the constant monitoring of impactors, vibrators and vibrating systems.

The *VibroMonitor* system reliably monitors the operation of vibrators and impactors, even in locations with difficult access.

Construction and Working Principle

The monitoring system consists of up to four sensors with connector cables (max. 250 m) to one control unit. The control unit supplies the sensors with the operating voltage and evaluates the sensors' signals.

The system displays two operating status informations per sensor: "Vibration" or "No vibration".

Permissible operating conditions

Operating voltage:
24 V DC (+20% / -10%), < 5% residual ripple
Ambient temperature:
C1W and C4W: 0°C to 40°C
C4 and S10: -20°C to 40°C

NetterVibration offers the accessories required for the mounting, installation, control and monitoring of vibrators and impactors.

Netter provides solutions.
Consult our experienced application technicians.

Netter GmbH

Germany

Fritz-Ullmann-Str. 9
55252 Mainz-Kastel
Tel. +49 6134 2901-0
Fax +49 6134 2901-33

Switzerland

Erlenweg 4
4310 Rheinfelden
Tel. +41 61 8316200
Fax +41 61 8311291

Poland

Al. W. Korfanteq 195/17
40-153 Katowice
Tel. +48 32 2050947
Fax +48 32 2051572

www.*NetterVibration*.com
info@*NetterVibration*.com

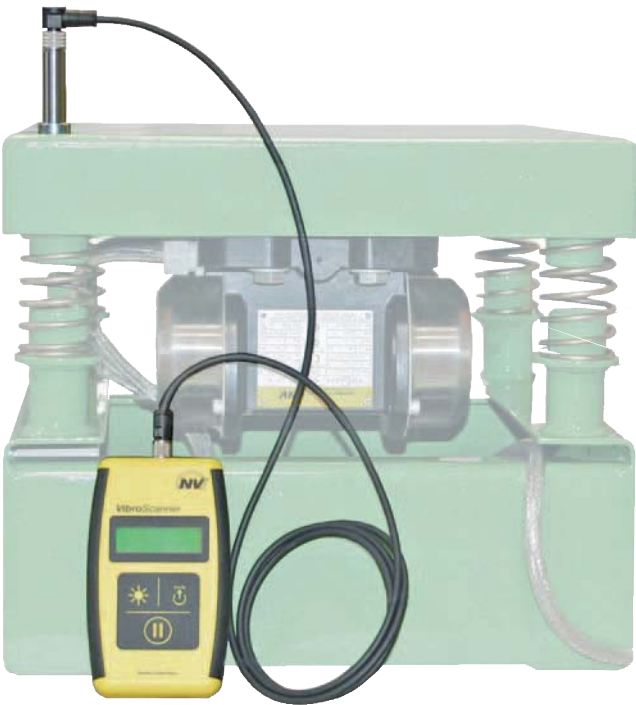

39

Netter Vibration Measuring System Series *VibroScanner*



- Acceleration measurements
- Frequency measurements
- Process control



Probe tips



Sensor



Scanner



Netter Vibration Measuring System Series *VibroScanner*

VibroScanner



Metering	Root mean square (RMS)	
Ranges	Acceleration measurement	-15 ... 15 g _e (-147 ... 147 m/s ²)
	Frequency measurement	5 ... 800 Hz / +/- 0,1 Hz
	Amplitude measurement	+/- 0,1 mm (at sinus)
Resolution	+/- 0,1 g _e (+/- 1 m/s ²)	
Measuring accuracy	+/- 3 %	
Damping	-2 dB at 800 Hz	

Standard equipment:

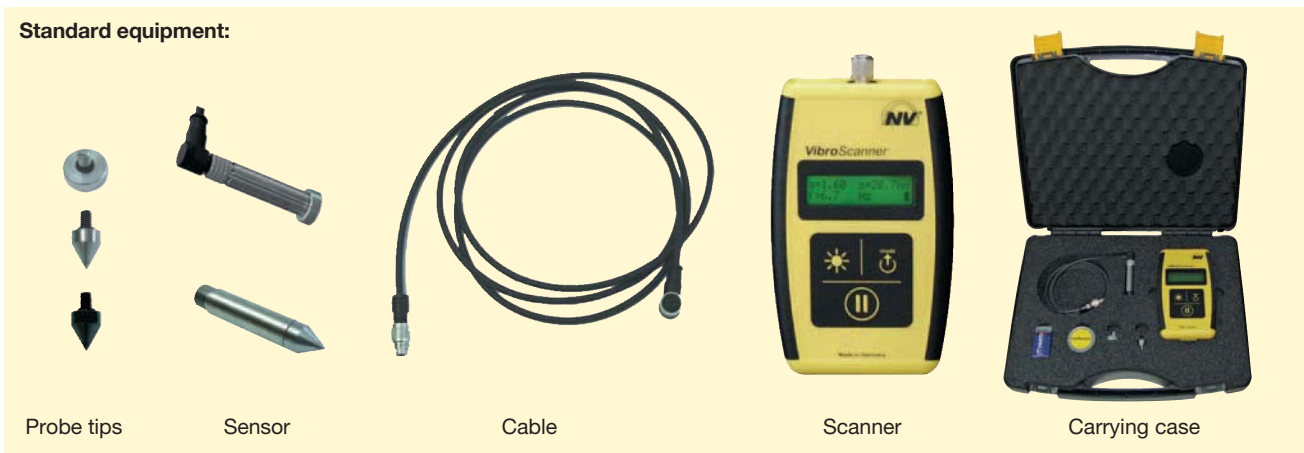

Probe tips

Sensor

Cable

Scanner

Carrying case

Applications

The *VibroScanner* is used to measure the acceleration and the dominant frequency of mechanical vibrations by means of an acceleration sensor.

Possible applications are the measurement of the operational parameters of vibration systems, e.g. frequencies and effective accelerations in vibration feeders and conveyors, vibration compactors or vibration test systems. Thereby, the *VibroScanner* permits a quantitative process control on a regular basis, thus contributing essentially to the long successful operation of the vibration system. Moreover, it makes it possible for plant manufacturers to perform batch controls in vibration drives in order to ensure a consistent product quality.

Design and function

The sensor used is a capacitive micro-mechanical (MEMS) sensor characterized by high mechanical strength. The signal processing takes place directly in the sensor housing, thus reducing considerably the sensitivity to electrical interference.

Admissible operating conditions

Operating voltage:

9 V battery

Ambient temperature:

-20°C to 40°C

NetterVibration offers the accessories required for the mounting, installation, control and monitoring of vibrators and impactors.

Netter provides solutions.

Consult our experienced application technicians.

Netter GmbH

Germany

Fritz-Ullmann-Str. 9
55252 Mainz-Kastel
Tel. +49 6134 2901-0
Fax +49 6134 2901-33

Switzerland

Erlenweg 4
4310 Rheinfelden
Tel. +41 61 8316200
Fax +41 61 8311291

Poland

Al. W. Korfantego 195/17
40-153 Katowice
Tel. +48 32 2050947
Fax +48 32 2051572

www.NetterVibration.com
info@NetterVibration.com

You have the opportunity for a free demonstration or trial of our devices, with no further obligation. In order for us to serve you quickly and effectively, we request that you complete this questionnaire.

Application

Emptying bunkers (Provide main dimensions on reverse)
Slides / chutes (Provide main dimensions on reverse)
Compaction of

Material Consistency

Specific weight kg/l% moistness

<input type="checkbox"/> dry	<input type="checkbox"/> sticky	<input type="checkbox"/> granulated
<input type="checkbox"/> moist	<input type="checkbox"/> slimy	<input type="checkbox"/> can be trickled
<input type="checkbox"/> dusty	<input type="checkbox"/> flaky	<input type="checkbox"/> splintery
<input type="checkbox"/> powdery	<input type="checkbox"/> fine-grained	<input type="checkbox"/> coarse-grained

Environmental Conditions

<input type="checkbox"/> normal	<input type="checkbox"/> ambient temperature°C
<input type="checkbox"/> warm radiation	<input type="checkbox"/> very damp (water spray)
<input type="checkbox"/> corrosive atmosphere	<input type="checkbox"/> Ex protection required
<input type="checkbox"/> other	

Pneumatic Vibrators

What is the operating pressure of your compressor system? bar

What is the power of your compressor?

(Alt. enter kW) m³/min (induced air)

How high is the loading of your compressor? low normal to the limit

Must exhaust air be dissipated? yes no

Electric Vibrators

Which type of voltage is required?

230 V, 3-phase 230/400 V, 50 Hz special voltage

Which vibrators are you particularly interested in?

<input type="checkbox"/> Pneumatic vibrators	<input type="checkbox"/> Electric vibrators
<input type="checkbox"/> Hydraulic vibrators	<input type="checkbox"/> The most suitable device dependant on application



NetterVibration

If you have already performed tests or currently work with other vibrators, please enter the following details:

Frequency vibrations/min
Centrifugal force N
Drive electric pneumatic

If these data are not known, please enter the type and manufacturer
Type:..... Manufacturer:.....

What improvements or modifications do you expect? What are you not pleased about?

Sketch (include extra sheet if necessary)
Please enter main dimensions!

Company

Name:

Street:

Department:

Town:

Who is directly responsible for this matter?

Telephone:

Date:

Name:

Required

- Offer with proposal
- Test device(s)
- Demonstration

Netter GmbH

Germany

Fritz-Ullmann-Str. 9
55252 Mainz-Kastel
Tel. +49 6134 2901-0
Fax +49 6134 2901-33

Switzerland

Erlenweg 4
4310 Rheinfelden
Tel. +41 61 8316200
Fax +41 61 8311291

Poland

Al. W. Korfantego 195/17
40-153 Katowice
Tel. +48 32 2050947
Fax +48 32 2051572

www.**NetterVibration**.com
info@**NetterVibration**.com

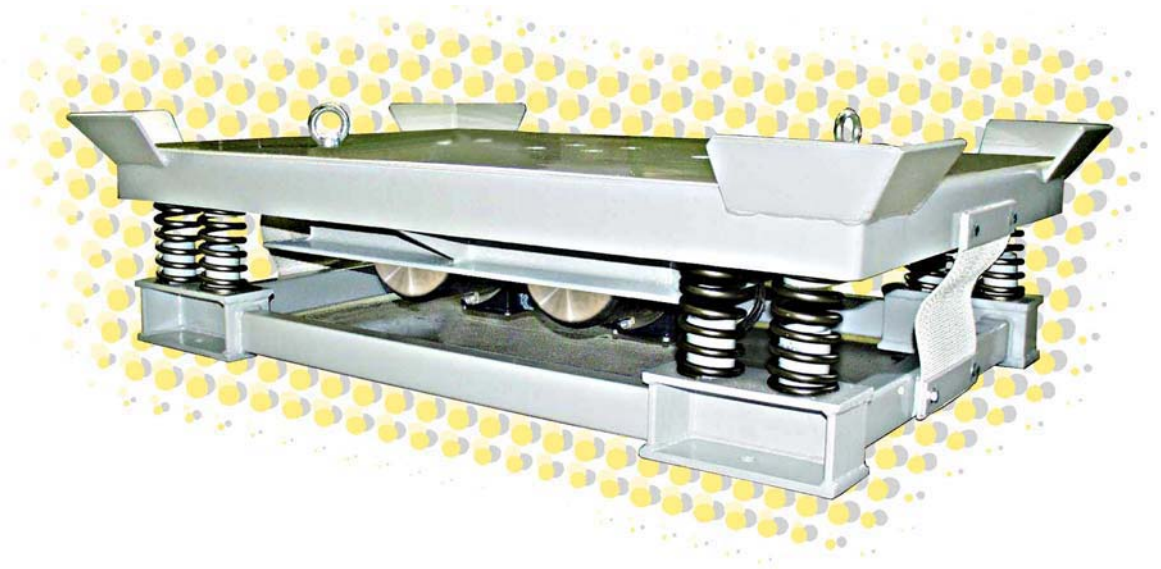

41

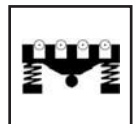

Netter Vibrating Tables Series VT

- Elektric or pneumatic drives
- Variable centrifugal force
- Adjustable vibration amplitude
- Directional or circular rotation
- Optimum vibration insulation
- Low noise
- Low overall height
- Robust versions for continuous operation
- Various controls and accessories
- Movable



VTP 3/3
with NTS 350 NF
pneumatic



VTF 8/8
with 2 NTS 50/08
flat design



VT 7/8
with 2 NEG 50770
electric



Netter Vibrating Tables Series VT

A small extract from our range of vibrating tables

Version	Type	Vibrator	Length [mm]	Width [mm]	Height [mm]	Vibrations	Weight [kg]
Electric	VTE 3/3	NEG 50120	300	300	273	circular	20
	VTE 6/6	2xNEG 2570	600	600	273	vertical directional	41
	VTE 8/12	2xNEG 25930	800	1200	350	vertical directional	290
Pneumatic	VTP 3/3	NTK 18 AL	300	300	350	vertical directional	22
	VTP 5/5	NTS 50/01	500	500	350	vertical directional	31
	VTP 10/10	NTS 50/08	1000	1000	300	vertical directional	185

All sizes: A special feature is the flat construction, with heights from just 80 mm on.

Loads: 1 to 20.000 kg

Materials: Painted or galvanized sheet steel and pickled stainless steel

Controls: Electric switch cabinet with:

- On/Off switch with motor protection relay
- Frequency control and display
- Brakes
- Timers
- Remote controls and much more.

Electro-pneumatic controls in terminal boxes:

- Control valves
- Throttles
- Maintenance units

Multiple-shaft vibration system



In individual cases, the required drive can only be determined by means of testing. We provide free test devices (excl. transport costs) for this purpose.

Design: The electric or pneumatic vibrators are attached to the inflexible plate of the vibrating table. The plate is connected to the base via a vibration-optimized spring suspension.

Applications

Electrical, Electronic and Precision Engineering Industries	
Inspection	of connections, individual parts or complete devices for cold solder spots, hairline cracks, functional errors, natural resonancies
Simulation	of transport movements, mechanical environmental influences
Untangling, separating, distributing, aligning	of small parts, such as screws, bolts, springs, hooks, rings, etc. prior to hand-assembly or automatic processing on assembly lines
Testing	of electrical components and devices (mechanical vibration tests)

Car Industry, Vehicle Construction	
Inspection (Durability tests)	of small add-on parts, such as carburetors, coils, valves, mechanical and electrical connections, safety devices, headlights, exterior mirrors, etc. for functional errors, hairline cracks, natural resonancies, wear

Food, Packaging and Chemical Industries	
Compaction	of loose products in small containers, such as barrels, cardboard drums, cartons, bags etc.
Flattening, distributing	of granules before closing packages
Loosening	of products which have become compacted during transport or storage, prior to further processing
Sedimentation	of solid materials out of suspensions
Levelling	of sacks and bags, prior to palletising or stacking

Construction industry	
Compaction	of concrete blocks, on the construction site or in the test laboratory



VTF/R 10/12 with 2 NEG 251370 E for applications conforming to ATEX



VTH/W 12/12 with 2 NEG 501510 for a weighing machine

NetterVibration offers the accessories required for the mounting, installation, control and monitoring of vibrators and vibrating tables.

Netter provides solutions. Consult our experienced application technicians.

Netter GmbH

Germany
Fritz-Ullmann-Str. 9
55252 Mainz-Kastel
Tel. +49 6134 2901-0
Fax +49 6134 2901-33

Switzerland
Erlenweg 4
4310 Rheinfelden
Tel. +41 61 8316200
Fax +41 61 8311291

Poland
Al. W. Korfantego 195/17
40-153 Katowice
Tel. +48 32 2050947
Fax +48 32 2051572

www.**NetterVibration.com**
info@**NetterVibration.com**

Netter questionnaire for the preparation of a quotation

please tag whatever is applicable

1. Application :

- **Compaction of bulk materials in containers**
- **Compaction of refractory materials**
- **Compaction of foundry moulding sand**
- **Compaction of prefabricated concrete parts**
- **Compaction of polymer concrete**
- **Levelling of pouring cones and distribution**
- **Flattening of bags**
- **Removal of sticky material on parts etc.**
- **Loosening of wire coils for further processing**
- **Separation of parts sticking together**
- **Cleaning off material sticking to work pieces**

Container:

- Type of container:
- Carton Cardboard drums Steel barrels Forms
- Octabins Containers Big Bags
- Other containers
- Dimensions (length • width • height): [mm]
- Weight: [kg]

Content :

- Product designation:
- Bulk weight: [kg/m³]
- Consistency:
 - powdery grainy doughy moist sticky bulky
- Weight of the total content: [kg]

Desired size of vibrating table:

- Size of vibrating plate (length • width): [mm]
- From top side of table plate to floor: [mm]

Installation situation:

Roller track

- Installation into existing roller track
- Vibrating table with roller track
- Roller diameter: [mm] Roller distance: [mm]
- Top edge of roller to floor: [mm] Width of roller track: [mm]
- not driven driven : Conveying speed: [m/min]

Scale

- Installation on a scale
- Installation above a scale
- Dimensions of scale (width • depth • height): [mm]



Pit

- Installation in a pit, top side of vibration table is level with floor
- Dimensions of pit (length • width • depth): [mm]
- Application of container:
 - Manual lift truck Fork lift truck Crane

Conveyor belt

- Installation into a conveyor belt
- Width of belt[mm] Distance between top and bottom belt [mm]
- Top side of upper belt to floor: [mm]

Other versions

- Flat design
- Desired height from top side of table plate to floor: [mm]
- Portable version
- Moveable

• Tests, material and product tests

- Mechanical vibration test according to own requirements or standards.
- Simulation of transport movements or environmental influences.
- Other application:
- Desired frequency:
 - Fixed frequency in [Hz] or [oscillations / min.]
 - Controllable up to in [Hz] or [oscillations / min.]
- Desired acceleration:[a_(g) = multiple of the acceleration due to gravity]
- Desired oscillation width:[mm]
- Desired direction of oscillation:
 - circular vertical directed vertical
 - circular horizontal directed horizontal
- Desired timing range or number of cycles (please describe) :
.....

• Other applications

Please describe, if possible add a sketch:.....
.....
.....

2. Environmental influences (please describe) :

- Ambient temperature: [°C]
- Humidity (e.g. spray water):
- Caustic atmosphere:
- Other environmental influences:

3. Type of drive :

- *Compressed air*
 - Available pressure: [bar]
 - Supply quantity: [m³ / min]
- *Electric*
 - Available voltage and mains frequency: [V] [Hz]
 - Explosion protection , if yes: Information about the explosion protection class:

4. Control :

- By customer Specify interface:
- Offer

5. Address :

Company :.....
Name :.....Department :.....
Country:
Place :.....
Street :.....
Phone :..... Fax :.....
Internet address:..... E-mail :.....

Netter GmbH

Germany
Fritz-Ullmann-Str. 9
55252 Mainz-Kastel
Tel. +49 6134 2901-0
Fax +49 6134 2901-33

Switzerland
Erlenweg 4
4310 Rheinfelden
Tel. +41 61 8316200
Fax +41 61 8311291

Poland
Al. W. Korfantego 195/17
40-153 Katowice
Tel. +48 32 2050947
Fax +48 32 2051572

www.**NetterVibration.com**
info@**NetterVibration.com**



44

Netter Dosing Station Series *DosyPack*



- Exact dosing
- High conveying performance
- Gentle and uniform dosing
- Adjustable fine or coarse flow
- All product-carrying parts made of stainless steel 1.4301
- High surface quality
- Quick and easy to clean



*DosyPack*4



DosyPack 40



DosyPack 56



Netter Dosing Station Series *DosyPack*

Example	Product Characteristics		Feed Rate [g/s]		Noise Level [dB(A)]
	Grain Density [kg/dm ³]	Grain Size [mm]	<i>DosyPack</i> 4	<i>DosyPack</i> 25 bis 80	
Sand	1,54	0 - 1	0 - 20	0 - 260	56 - 75
Granulate	0,70	1 - 3	-	0 - 150	56 - 75
Plastic caps	0,20	Ø 10	-	0 - 25	56 - 73

The technical data relate to the examples given and can vary, depending on the product.

Type	A [mm]	B [mm]	ØC [mm]	D [mm]	E [mm]	□F [mm]	G [mm]	V (Container volume) [l]	Weight [kg]
<i>DosyPack</i> 4	420	480	200	190	175	290 x 150	105	4	5,5
<i>DosyPack</i> 25	729	710	381	241	190,5	430 x 280	261	25	15,0
<i>DosyPack</i> 40	729	860	381	241	190,5	430 x 280	261	40	16,8
<i>DosyPack</i> 56	805	844	533	241	190,5	430 x 280	261	56	26,3
<i>DosyPack</i> 80	805	994	533	241	190,5	430 x 280	261	80	29,5



Dosing port at the silo outlet

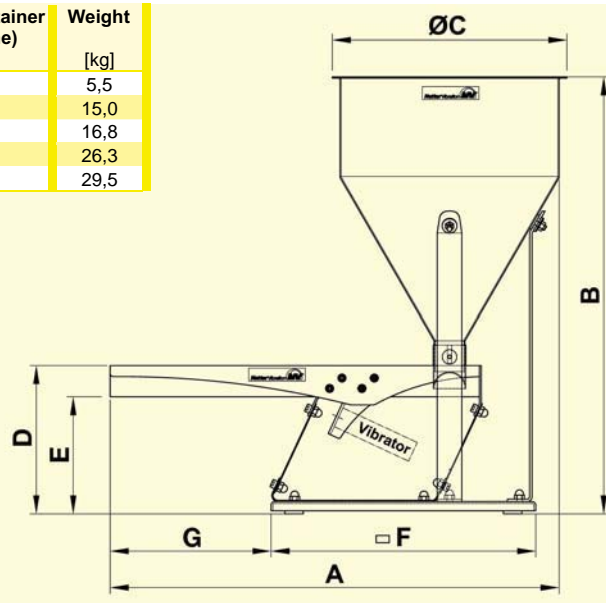

Applications

DosyPack dosing stations are particularly suitable for the fast and exact dosing of all types of bulk material, or as feeders for optical sorting facilities. Gentle dosing is possible for especially sensitive products.

Design and functioning principle

The dosing station basically consists of a conveyor channel mounted on leaf springs and a silo. All product-carrying parts are made of brushed stainless steel ($R_a=0,25$, $R_z=1$), all other parts are made of corrosionresistant and physiologically harmless materials.

Because of the functional design *DosyPacks* are fast and easy to clean. This allows it to be used even under the extreme hygienic conditions demanded by the chemical, pharmaceutical and food industries.

The flow rate can be varied with the dosing port at the silo outlet.

Pneumatic linear vibrators series NTS and NTK may be selected for driving. They work without running on, so that the product flow is immediately interrupted, once the vibrators are switched off.

The exact feed quantity is regulated by adjusting the frequency and amplitude of vibration. Both can be independently adjusted. Increasing the supply pressure causes an increase in the frequency. The amplitude can be adjusted by regulating the optional throttle.

A multi-directional valve is required for operation (not supplied).

In addition to the standard versions, series *DosyPack* dosing stations are also available in customized designs. Furthermore, all individual components can be supplied separately.

Permissible operating conditions

Drive medium:

Compressed air or nitrogen (filter $\leq 5 \mu\text{m}$), preferably with oil mist

Operating pressure:

2 bar to 6 bar

Ambient temperature:

5°C to 60°C

NetterVibration offers the accessories required for the mounting, installation, control and monitoring of vibrators and impactors.

Netter provides solutions.

Consult our experienced application technicians.

Netter GmbH

Germany

Fritz-Ullmann-Str. 9
55252 Mainz-Kastel
Tel. +49 6134 2901-0
Fax +49 6134 2901-33

Switzerland

Erlenweg 4
4310 Rheinfelden
Tel. +41 61 8316200
Fax +41 61 8311291

Poland

Al. W. Korfantego 195/17
40-153 Katowice
Tel. +48 32 2050947
Fax +48 32 2051572

www.*NetterVibration*.com
info@*NetterVibration*.com

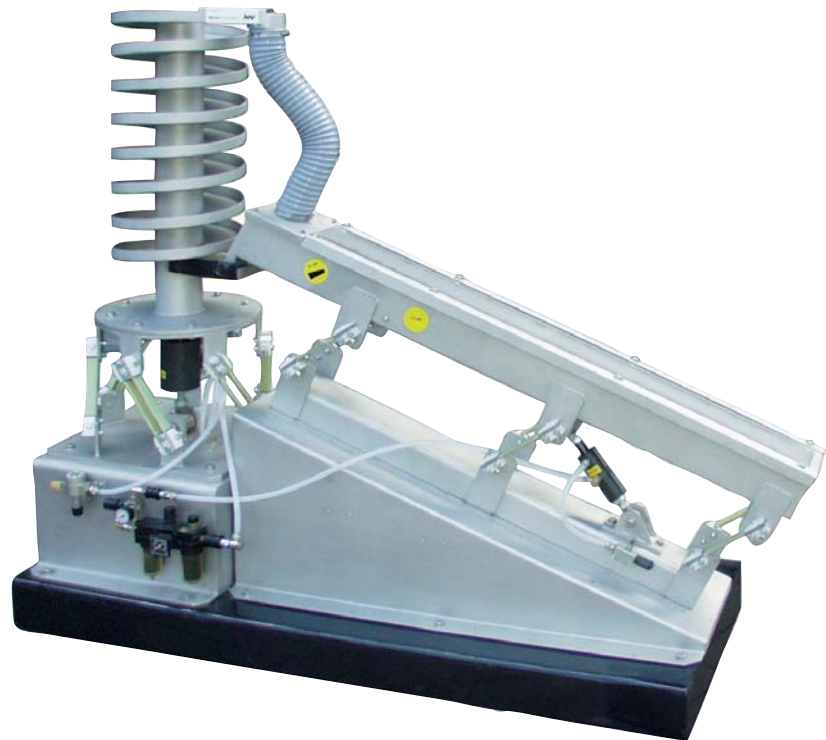

45

Netter Resonance Conveyor System Series *FlexiLink*



- High conveying performance by use of spring resonance
- Low air consumption
- Immediate starting and stopping
- Low unit weight





NetterVibration



Netter Resonance Conveyor System Series *FlexiLink*

Netter resonance conveyor systems in the FlexiLink series consist of:

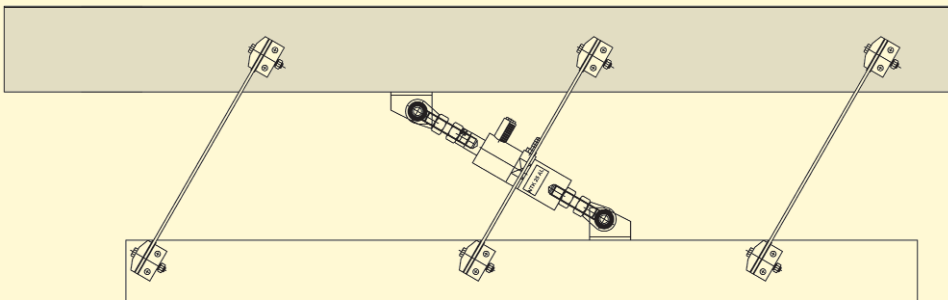

A conveyor trough, manufactured either by the client or as per the client's requirements

blade springs,
a pneumatic linear vibrator series NTK with the *FlexiLink* connecting element

and the counter-weight (frame/floor)

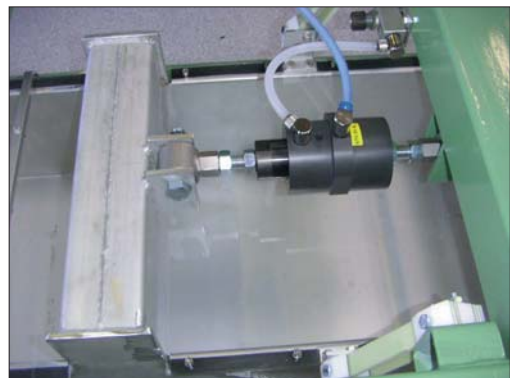

Applications

Conveyor systems of the *FlexiLink* series serve to convey bulk material efficiently and gently.

Design and functioning principle

The feeder system consists of a pneumatic linear vibrator of series NTK, blade springs and the *FlexiLink* connecting element.

This system uses the natural resonance of the springs in order to convey bulk materials. Once the trough starts to vibrate at the resonance frequency, very little additional energy is required to maintain the vibration. Even with varying loads, the trough continues to vibrate in resonance.

The amplitude can be adjusted by means of an optional exhaust throttle.

In addition to driving classic feeder troughs, the *FlexiLink* system can also be used to drive spiral feeders. The blade springs are then arranged in a circle in order to

accommodate the spiral feeder.

In addition to the standard versions, customized variants of the *FlexiLink* series are also available. Furthermore, all components can be supplied separately.

Permissible operating conditions:

Drive Medium:

Compressed air or nitrogen (filter $\leq 5 \mu\text{m}$), preferably with oil mist

Operating pressure:

2 bar to 6 bar

Ambient temperature:

5°C to 60°C

NetterVibration offers the accessories required for the mounting, installation, control and monitoring of vibrators and impactors.

Netter provides solutions.

Consult our experienced application technicians.

Netter GmbH

Germany

Fritz-Ullmann-Str. 9
55252 Mainz-Kastel
Tel. +49 6134 2901-0
Fax +49 6134 2901-33

Switzerland

Erlenweg 4
4310 Rheinfelden
Tel. +41 61 8316200
Fax +41 61 8311291

Poland

Al. W. Korfantego 195/17
40-153 Katowice
Tel. +48 32 2050947
Fax +48 32 2051572

www.NetterVibration.com
info@NetterVibration.com

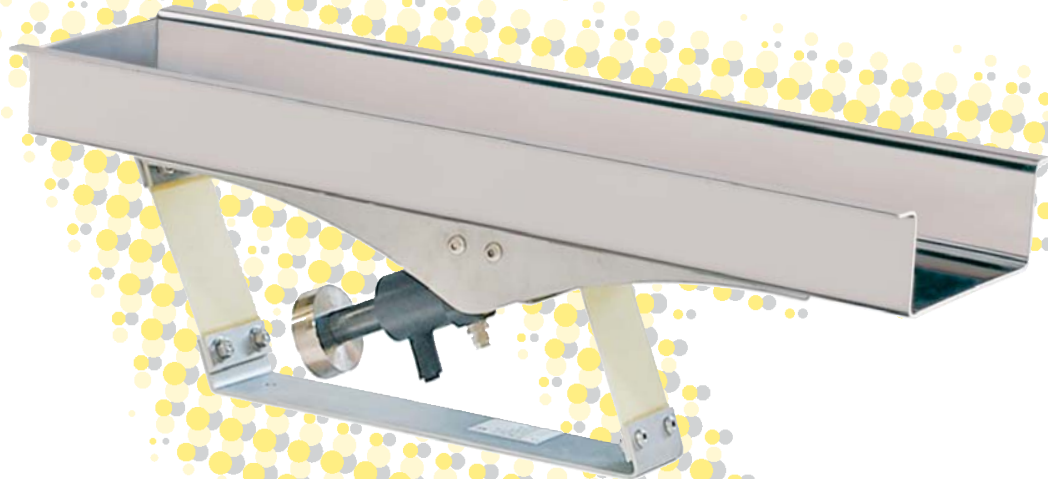

46

Netter Conveyor Systems Series *PowerPack*



- Gentle and smooth conveying
- Coarse and fine flow settings
- Instant starting and stopping
- Stainless steel version possible





NetterVibration



Netter Conveyor Systems Series *PowerPack*

Type	A [mm]	B [mm]	C [mm]	D [mm]	E [mm]	F [mm]	G [mm]	ØH [mm]	Weight without trough [kg]
PowerPack 180	500	170	85	80	343	230	93	9	ca. 2,1
PowerPack 250/350	580	173	100	80	442	321,5	94	9	ca. 3,6

Conveyor systems of the PowerPack series consist of:



A conveyor trough, manufactured either by the client or as per the client's requirements,

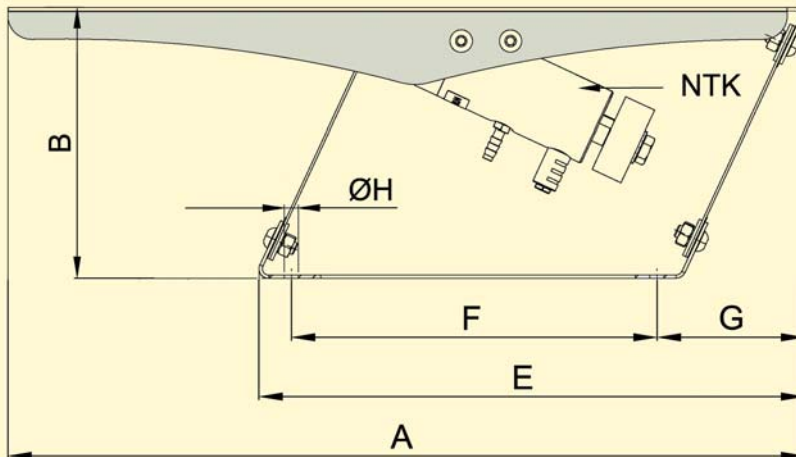
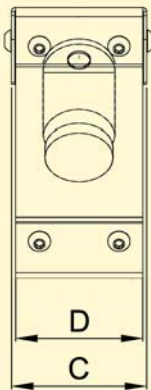

the upper part,
the blade springs,
pneumatic linear vibrators of series NTK or NTS
and the lower part.

Applications

Conveyor systems of the **PowerPack** series serve to convey bulk material efficiently and gently. The stainless steel version allows the operation in the chemical, pharmaceutical and food industries.

Design and functioning principle

The **PowerPack** feeder system works with forced vibrations. The conveyor trough is mounted on blade springs and is driven by a pneumatic linear vibrator of the NTK or NTS series. Depending on the application, it is also possible to use an electric external vibrator of the NEG series. The selection of the vibrator depends not only on the material properties, but also on the requested frequency or amplitude. Unlike many other conveyor systems, the frequency and amplitude of the **PowerPack** series can be controlled separately. It is therefore possible to satisfy many individual requirements.

In addition to the general standard versions, customized versions of the **PowerPack** series are also available. Furthermore, all components can be supplied separately.

Permissible operating conditions:

Drive medium:

Compressed air or nitrogen (Filter 5 µm), preferably with oil mist.

Operating pressure:

2 bar to 6 bar

Ambient temperature:

5°C to 60°C
HT versions up to 200°C

NetterVibration offers the accessories required for the mounting, installation, control and monitoring of vibrators and impactors.

Netter provides solutions.

Consult our experienced application technicians.

Netter GmbH

Germany

Fritz-Ullmann-Str. 9
55252 Mainz-Kastel
Tel. +49 6134 2901-0
Fax +49 6134 2901-33

Switzerland

Erlenweg 4
4310 Rheinfelden
Tel. +41 61 8316200
Fax +41 61 8311291

Poland

Al. W. Korfatego 195/17
40-153 Katowice
Tel. +48 32 2050947
Fax +48 32 2051572

www.**NetterVibration**.com
info@**NetterVibration**.com

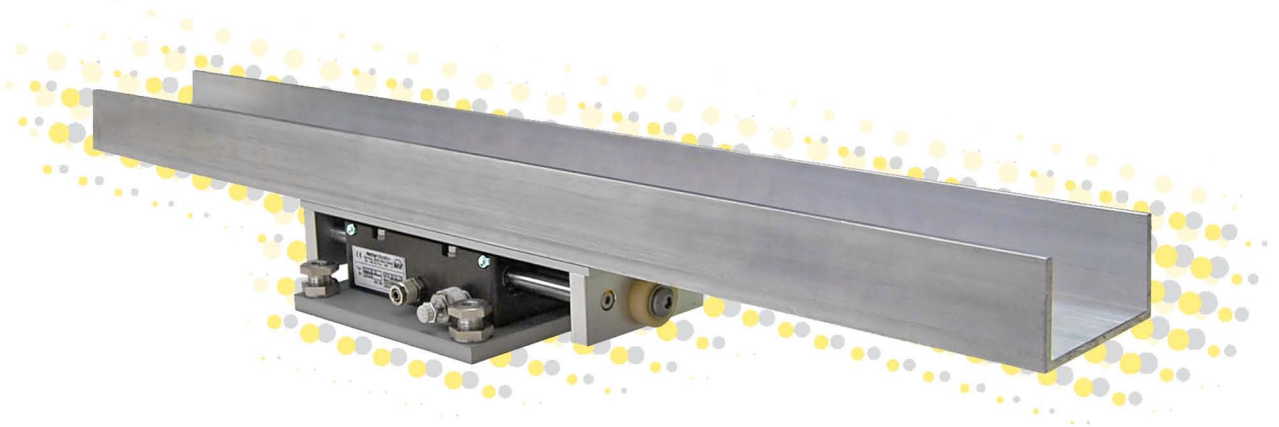

47

Netter Conveyor System Series *LineDrive*



- Gentle and constant conveying
- Flat, compact construction
- Modularly extendable
- Low air consumption
- Very low noise level





Netter Conveyor System Series *LineDrive*

The conveyor system of the **LineDrive** series consist of:

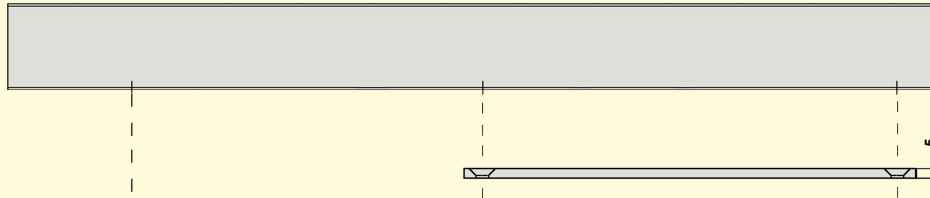

a conveyor trough, manufactured either by the client or as per client's requirements,

the mounting plate (optional)

LineDrive support NLD 25 A

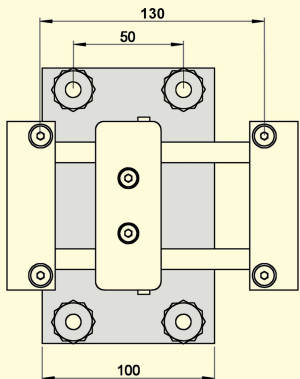
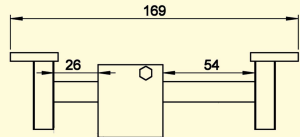

The LineDrive support is required as support for longer conveyors or for greater loads as well.

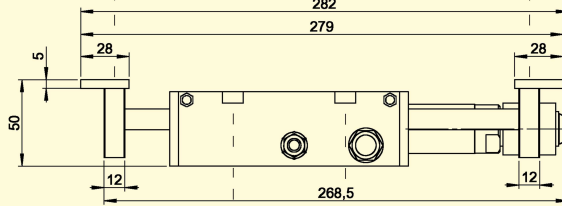

the **LineDrive** unit, driven by a linear vibrator

and the ground plate (optional).

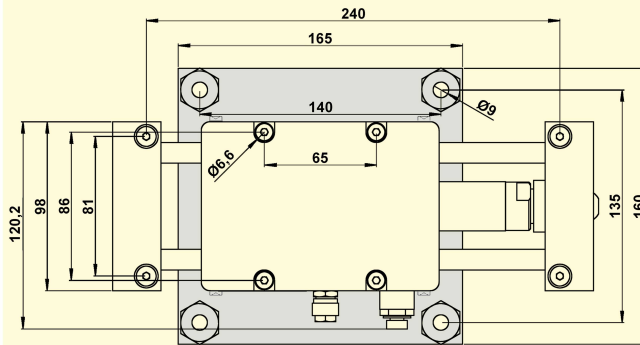

Conveyor system **LineDrive**



trough



mounting plate



drive unit



ground plate



support

Applications

The **LineDrive** conveyor system is suitable for gentle, horizontal conveying of bulk material. The flat design (height of drive 5 cm) allows applications even with confined space constraints.

Design and functioning principle

Traditional vibration conveyor systems work on the throwing principle, in which the product is "thrown" forward, following a trajectory parabola. With the **LineDrive** conveyor principle, the material slides along the conveyor trough. This is made possible by a pneumatic linear drive. The conveyor output can be adjusted to suit the specific characteristics of the material to be conveyed by regulating the compressed air. In longer conveyor systems (from approx. 2m), the trough is supported by the **LineDrive** support. It is possible to convey greater loads by coupling several **LineDrive** propulsion systems. In addition to the standard versions, customized variants of the **LineDrive** series are also available.

Mounting plates

The mounting plates are suitable for mounting the entire surface of the conveyor troughs on a **LineDrive** unit.

Baseplates

The base plates are used to compensate unevenness in order to avoid any tensioning in the **LineDrive** unit.

Permissible operating conditions:

Drive Medium:

Compressed air or nitrogen (filter $\leq 5 \mu\text{m}$), preferably with oil mist

Optimum Operating pressure:

2 bar

Ambient temperature:

5°C to 60°C

Weight without trough:

2,7 kg

NetterVibration offers the accessories required for the mounting, installation, control and monitoring of vibrators and impactors.

Netter provides solutions.

Consult our experienced application technicians.

Netter GmbH

Germany

Fritz-Ullmann-Str. 9
55252 Mainz-Kastel
Tel. +49 6134 2901-0
Fax +49 6134 2901-33

Switzerland

Erlenweg 4
4310 Rheinfelden
Tel. +41 61 8316200
Fax +41 61 8311291

Poland

Al. W. Korfantego 195/17
40-153 Katowice
Tel. +48 32 2050947
Fax +48 32 2051572

www.**NetterVibration**.com
info@**NetterVibration**.com